

92760 & 92884

Single 72 Pkt. Tower
with Flat Top and Base

PARTS BAG

PART	Quantity	Reference
Push Pin	13 (1 extra)	A
Trusshead Screw	9	B
Sign Holder	1	C

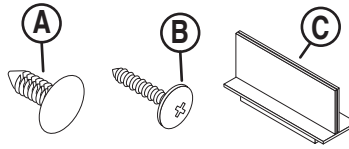

PARTS LIST

PART	Quantity	Reference
Tower Panel	3	D
Top	1	E
Base	1	F
Rack	72	G
Tower Helper	2	H

IMPORTANT: Peel protective masking off All Panels before assembly.

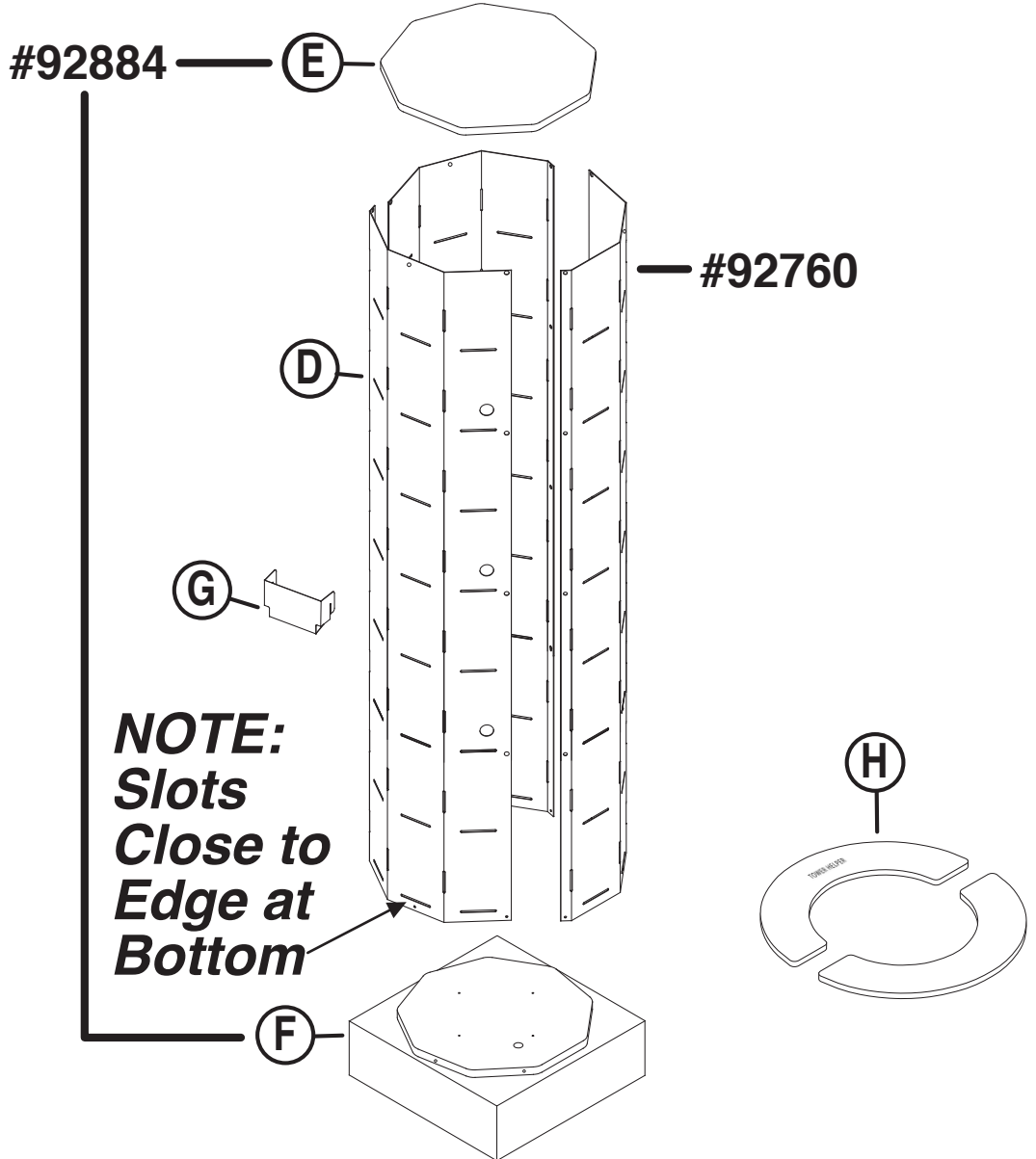
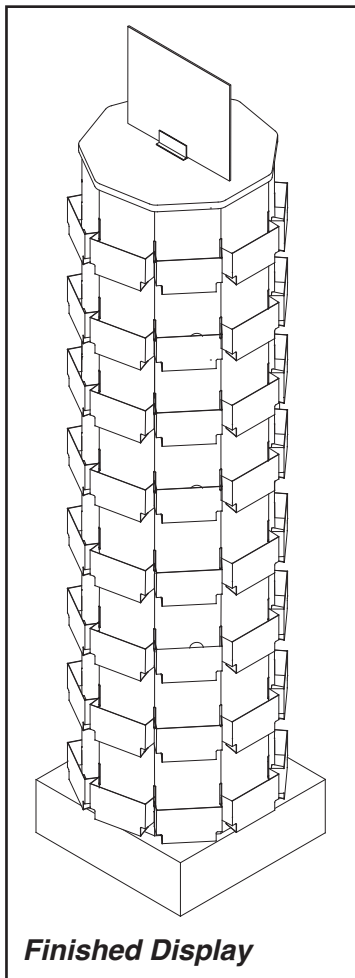

If you have any questions or need replacement parts, please call:
UPC Customer Service
1-800-859-7442

Design & Manufacture

U.S. PATENT NO.
8,534,472

If you have any questions or need replacement parts, please call:

UPC Customer Service
1-800-859-7442

Design & Manufacture

ASSEMBLY

- 1 A. Peel protective masking off **Tower Panels (D)** before assembly.
- B. Overlap each **Tower Panel (D)** so the large hole of facet lies outside the small hole of adjacent panel. (see figure BELOW)
- C. Use Large Finger Holes (see figure RIGHT) to hold **Tower Panels (D)** tightly together while installing **Push Pins (A)**.
- D. Join (3) **Tower Panels (D)** together using (12) **Push Pins (A)**. (see figure RIGHT)

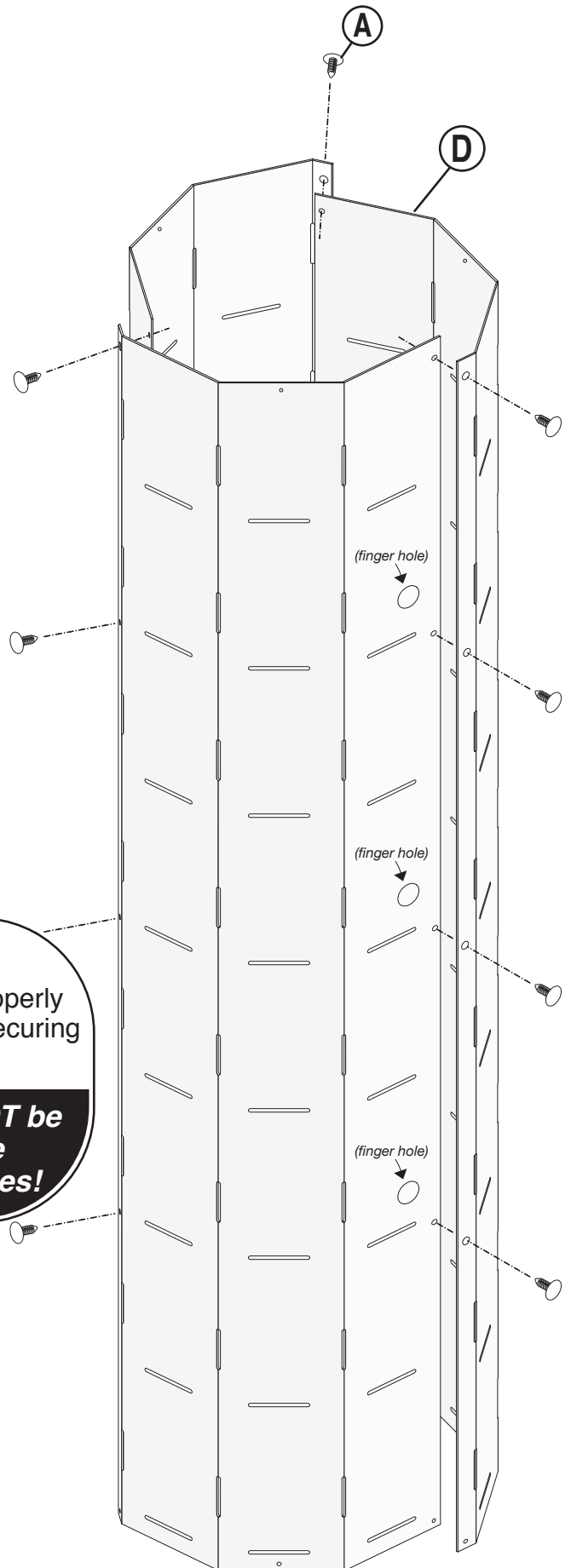

Small Hole
(align behind
Large Hole)

**Facet with
Large Hole**
(align in front
of Small Hole)

U.S. PATENT NO.
8,534,472

If you have any questions or need replacement parts, please call:

UPC Customer Service
1-800-859-7442

Design & Manufacture

ASSEMBLY

- 2** This step will hold **Tower Panel Assembly (D)** up for installation to Base Assembly. Insert (2) **Tower Helpers (H)** under Spinner Plate of **Base (F)** on base, as shown below.

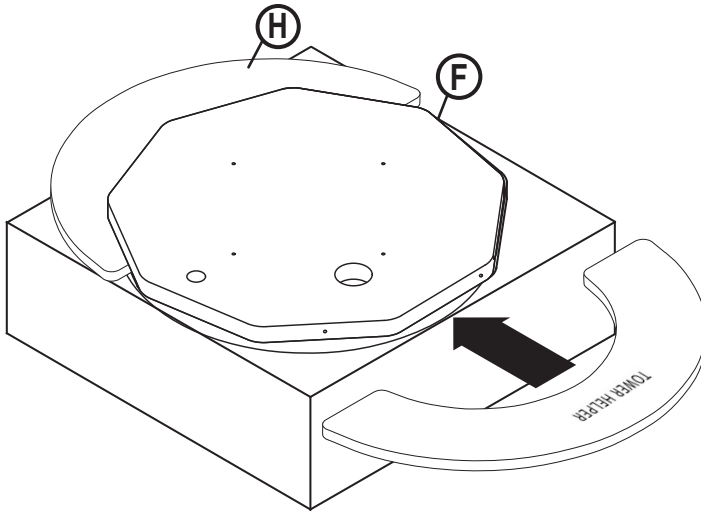

- 3** Align corresponding holes and set the **Tower Panel Assembly (D)** onto the Base Assembly.

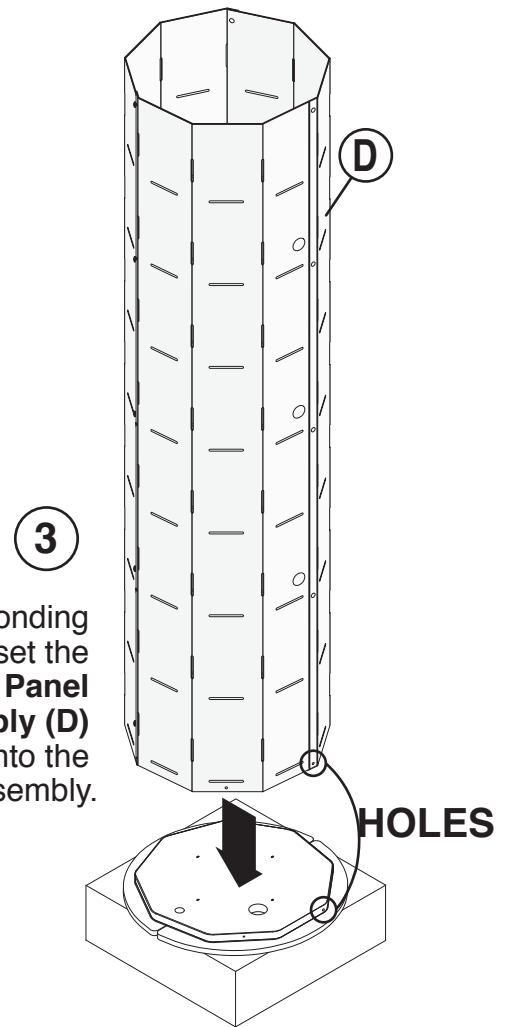

- 4** Secure **Tower Panel Assembly (D)** to Base Assembly at middle holes of Tower Panel Assembly. Attach **Tower Panel Assembly (D)** to Spinner Plate edge with (3) **Trusshead Screws (B)**. **DO NOT** tighten completely!

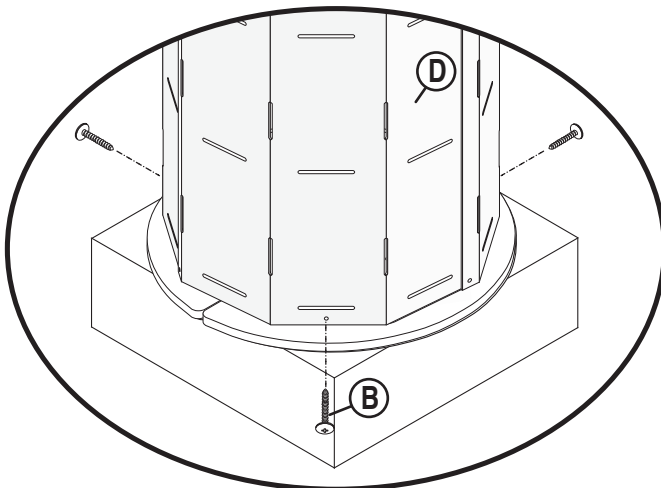

- 5** Continue to secure **Tower Panel Assembly (D)** to Base Assembly at corner holes of Tower Panel Assembly. Attach panels to Spinner Plate edge with (3) **Trusshead Screws (B)**. Tighten all (6) securely.

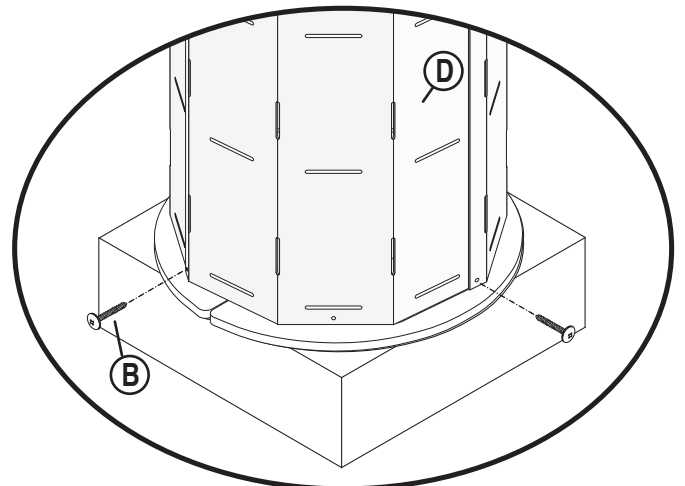

If you have any questions or need replacement parts, please call:

UPC Customer Service
1-800-859-7442

Design & Manufacture

ASSEMBLY

- 6 Remove **Tower Helpers (H)**.

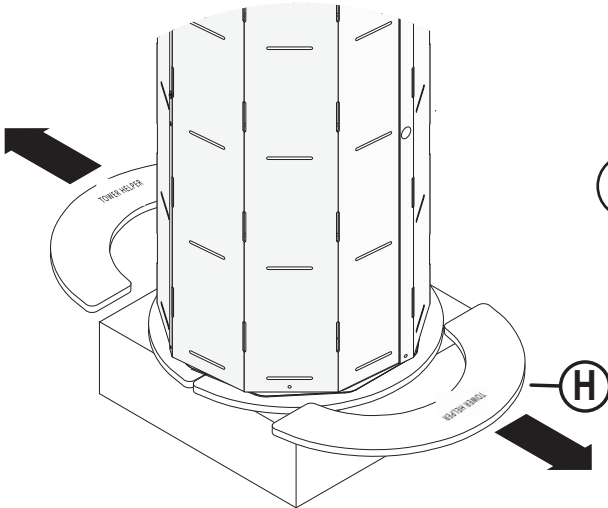

- 7 Align holes and lower **Top (E)** onto assembly. Secure to Body with (3) **Trusshead Screws (B)**.

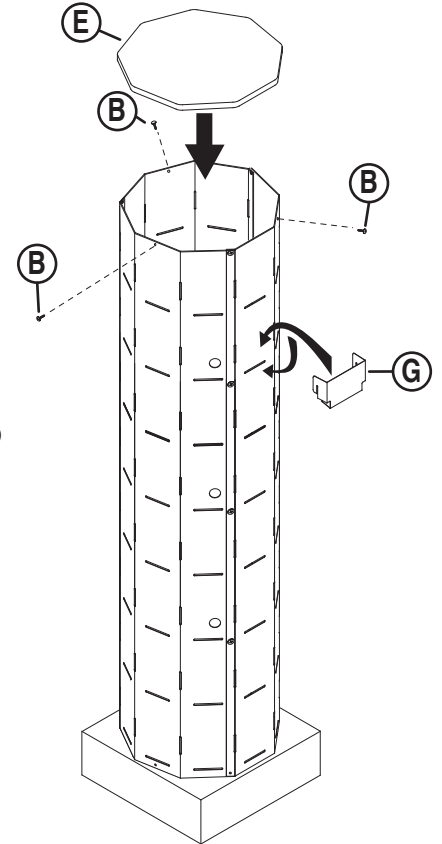

- 8 Attach (72) **Racks (G)** to assembly hooking sides into Vertical Slots and bottom tongue into Horizontal Slots.

Note: Each Vertical Slot will accommodate two adjacent **Racks (G)**.

- 9 Remove top layer of double stick tape on bottom of **Sign Holder (C)** & then press firmly to top of **Spinner Assembly** as shown right.

Insert Sign as shown right.

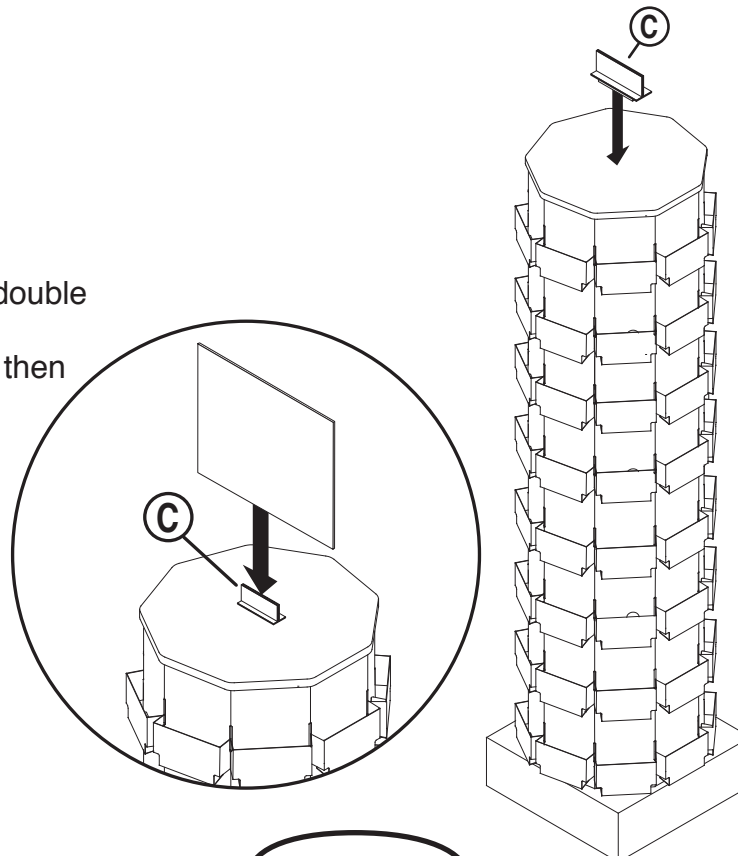

U.S. PATENT NO.
8,534,472