

!!! IMPORTANT !!!

IF YOU HAVE RECEIVED A

**99 POCKET WEDGE
ADD-ON UNIT
#8204**

WITH THIS FIXTURE

**DO NOT USE
THIS INSTRUCTION
SHEET.**

**YOU MUST USE THE INSTRUCTION
SHEET INCLUDED WITH THE ADD-ON
UNIT TO CORRECTLY ASSEMBLE AND
PROPERLY CONNECT THE TWO UNITS**

PARTS BAG **UPC#8203** **99 Pkt. Wedge Starter**

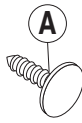
PART	Quantity	Reference	A
Push Pins	27	A	

PART	Quantity	Reference
Left Side	1	B
Right Side	1	C
Front	1	E
Clear Bottom Rack	1	F
Header	1	G
Back Brace	1	H
Racks	10	I
2-Tier Divider Strips	8	J
5-Tier Divider Strips	16	K

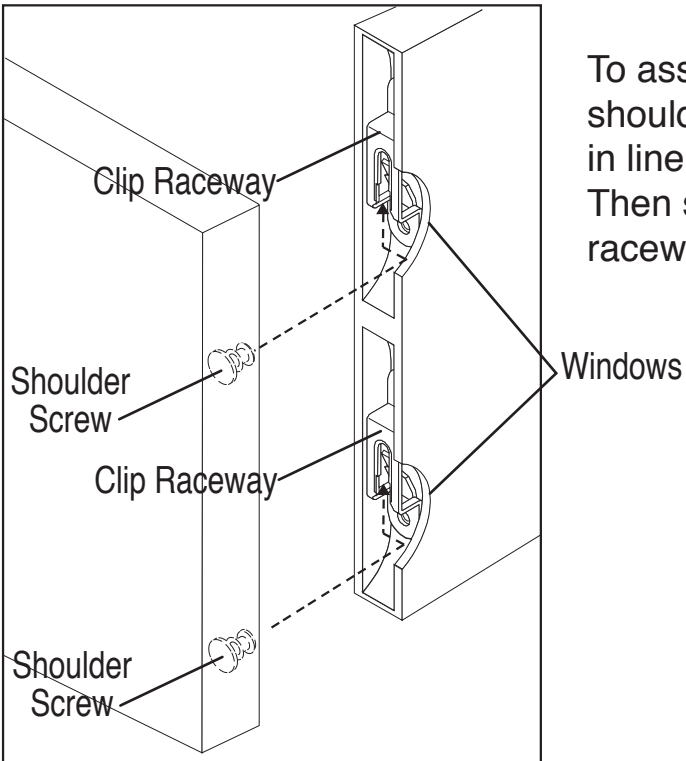
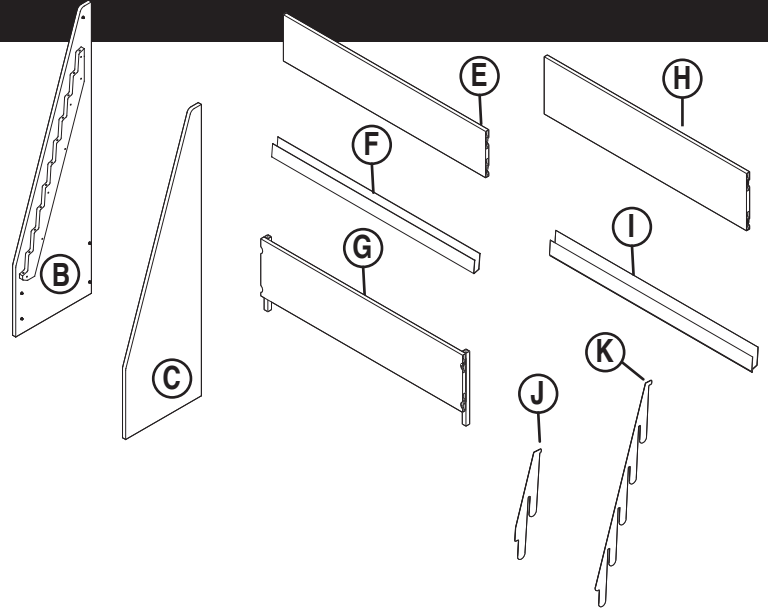

Connector Example

To assemble parts to side panels, slide the shoulder screws thru "Window" until they are in line with clip raceway. Then slide shoulder screws down into clip raceway until connector "clicks" locked.

MOD-EEZ FASTENER DISENGAGEMENT

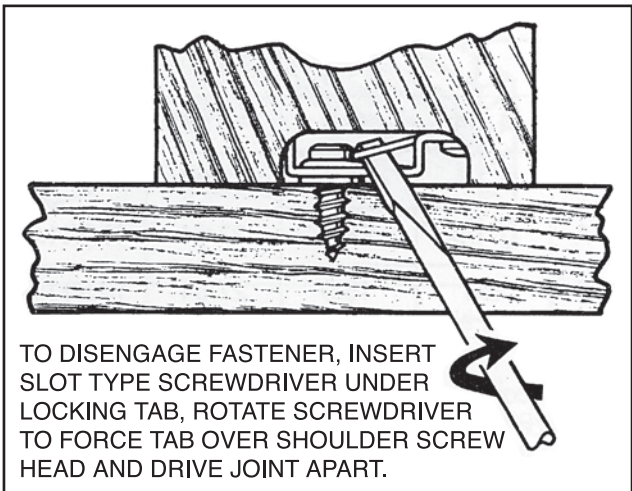

If you have any questions or need replacement parts, please call:

UPC Customer Service
1-800-859-7442

Design & Manufacture

ASSEMBLY

- 1 Attach both **Front (E)** and **Back Brace (H)** to **Left Side (B)**, as shown, then attach **Right Side (C)** to **Front (E)** and **Back Brace (H)**.

NOTE: Remember to face the "Windows" toward the back.

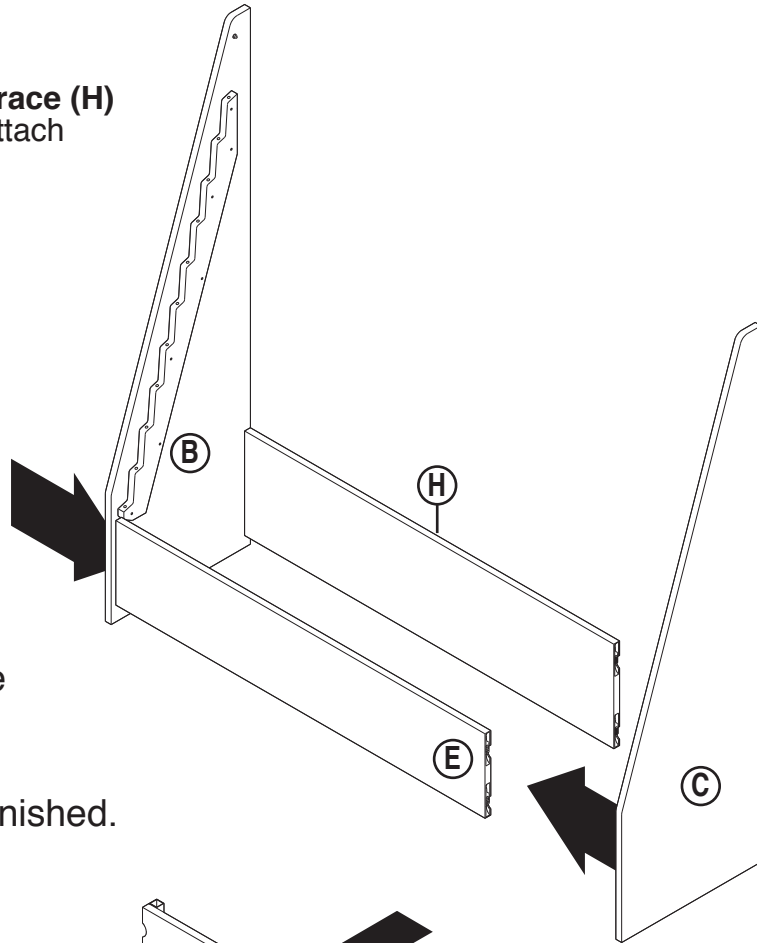

Important Note:

When assembling this fixture be sure all "windows" face the back, **EXCEPT THE HEADER (G)** so that they are not visible when display is finished.

- 2 Attach **Header (G)** to **Left & Right Sides (B & C)**.

NOTE: THE METAL BRACKETS FACE THE REAR.

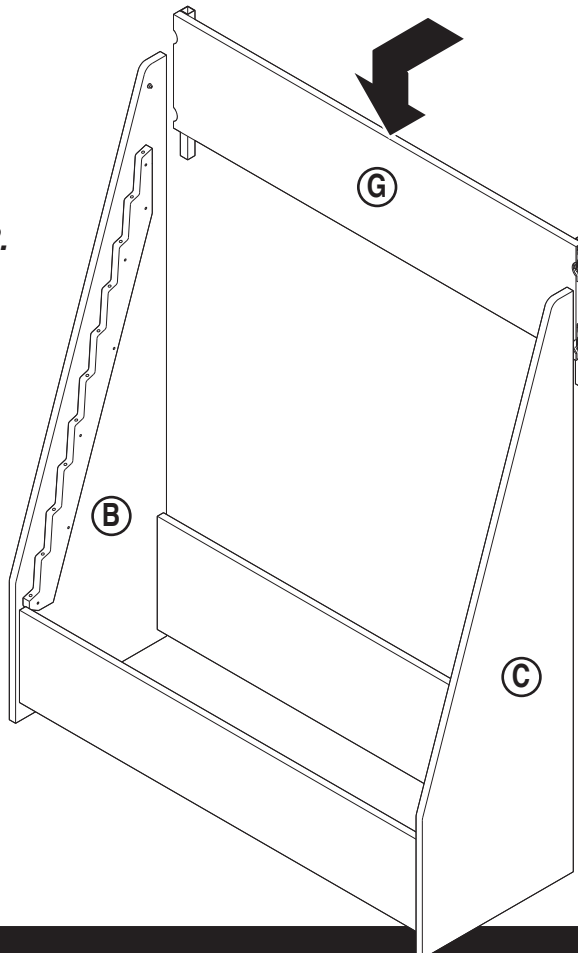

If you have any questions or need replacement parts, please call:

UPC Customer Service
1-800-859-7442

Design & Manufacture

ASSEMBLY

- 3 Install Racks (F & I) with Push Pins (A) starting with the Clear Bottom Rack (F) and working your way up.

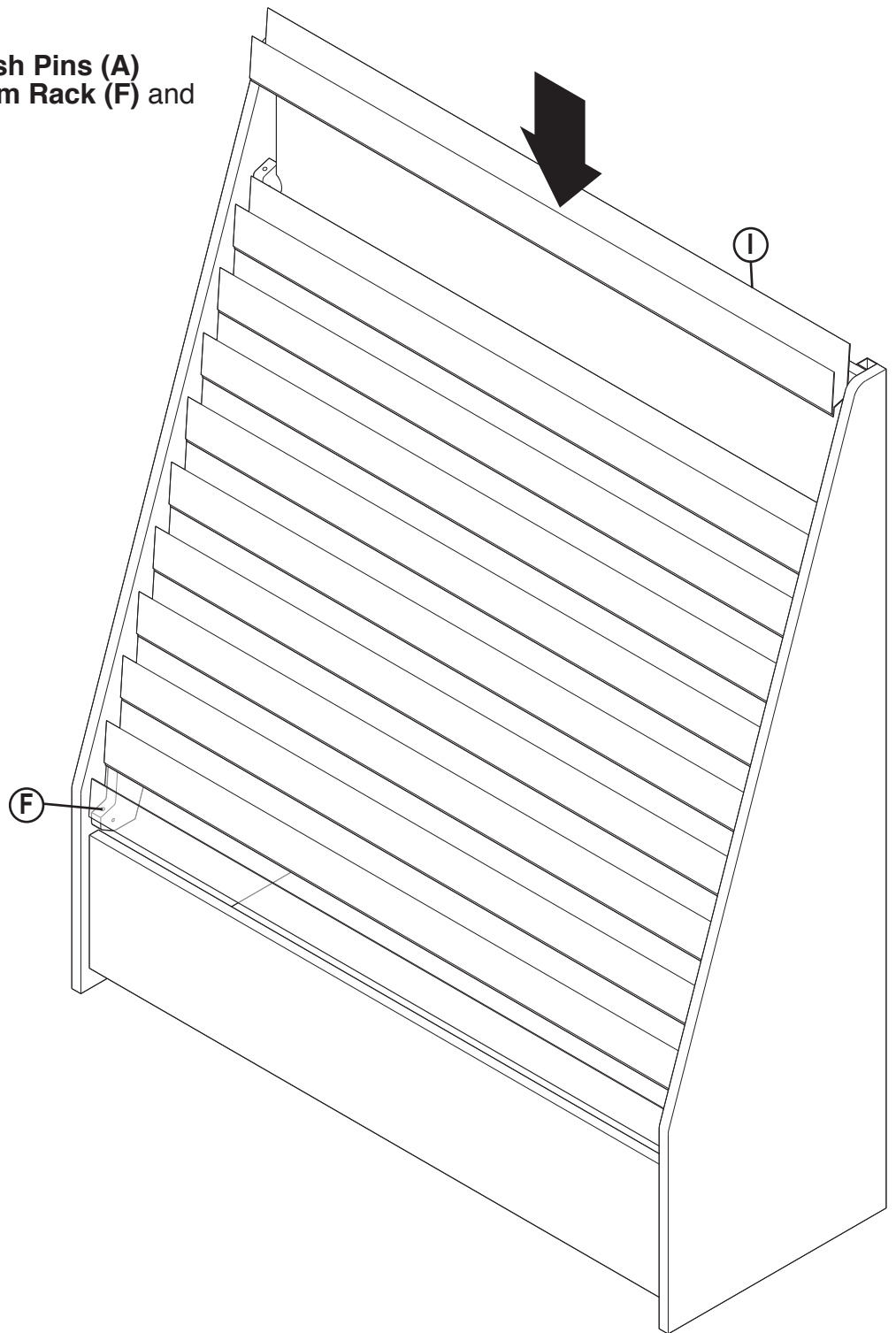
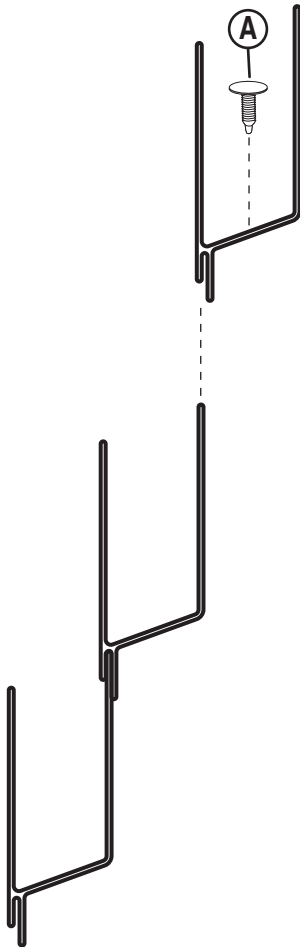

NOTE: Make sure racks lock together as shown in illustration above.

If you have any questions or need replacement parts, please call:

UPC Customer Service
1-800-859-7442

Design & Manufacture

ASSEMBLY

- 4 Install **5-Tier Divider Strips (K)** in bottom 10 racks on **Racks (F & I)**. Then install **2-Tier Divider Strips (J)** in the top 2 racks.

