

Thank you for your purchase of one of many fine products designed & manufactured by UPC. We have made every effort to make your assembly easy, clear & hassle free. For more information or if you have any questions contact customer service at 1-800-859-7442.

PARTS BAG UPC 8089 4' 11 Tier Inline Base Kit

PART	Quantity	Reference
Connector Bolt	12	A
Nut	4	B
3/8" Trusshead Screw	4	C
3/4" Wood Screw	16	D
Push Pins	25 (3 extra)	E
Key	2	F
Leveler	4	G
Left Bracket	1	H
Right Bracket	1	I
Connector Nut	2	J
Connector Bolt - Machine	2	K
Hex Wrench	1	L
Bolt Caps	4	W

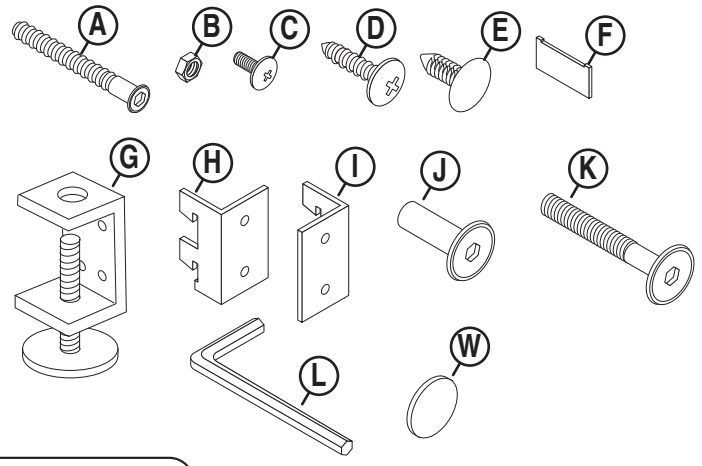

TOOLS REQUIRED: #2 Phillips & Flatblade Screwdriver

PARTS

PART	Quantity	Reference
Side Panel	2	M
Lower Rear Panel	1	N
Upper Rear Panel	1	O
Front Panel	1	P
Clear Rack	1	Q
White Rack	10	R
Slotted Upright	2	S
Sign Track	1	T
3 Tier Divider	16	U
5 Tier Divider	8	V

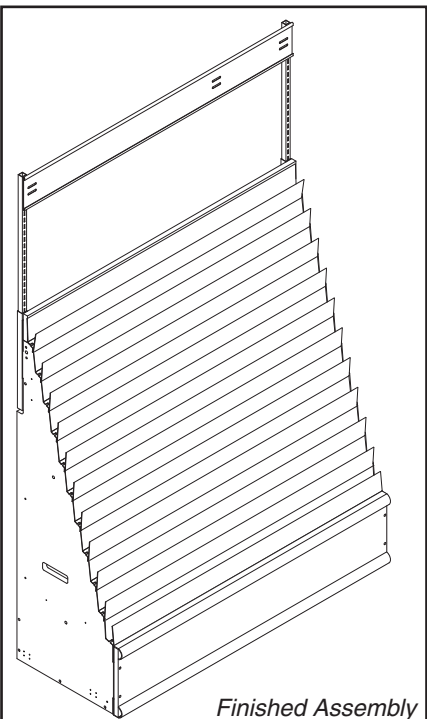
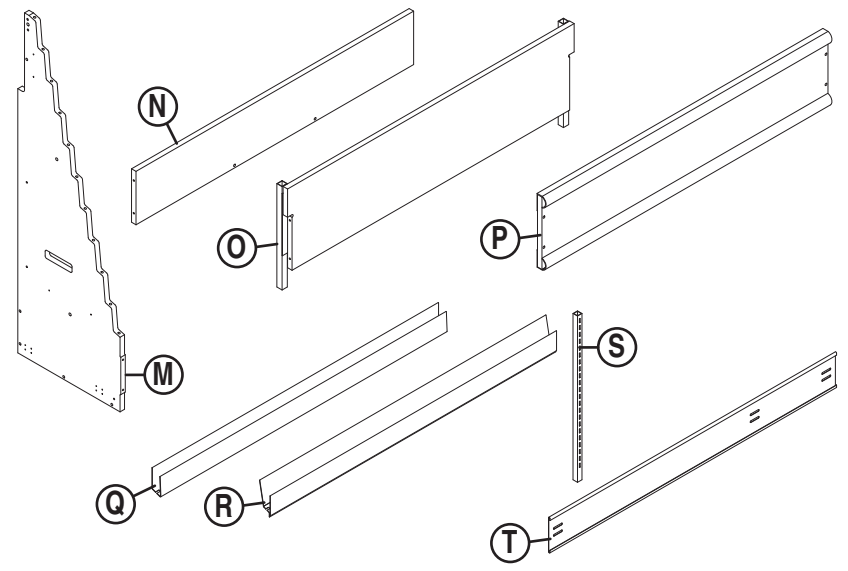

NOTE:
If using Optional Storage Base 8088, assembly must be correctly leveled with adequate space for door clearance. Units with Storage Bases should be built and placed first, because connecting units must be adjusted accordingly. See Instructions included with Storage Base BEFORE PROCEEDING!

YouTube
Instruction Video

Watch our easy to follow instruction video

www.upcdisplays.com/8089

If you have any questions or need replacement parts, please call:

UPC Customer Service
1-800-859-7442

Design & Manufacture

ASSEMBLY

- 1 Attach (4) Levelers (G) to "inside" faces of (2) Side Panels (M), using (16) 3/4" Wood Screws (D).

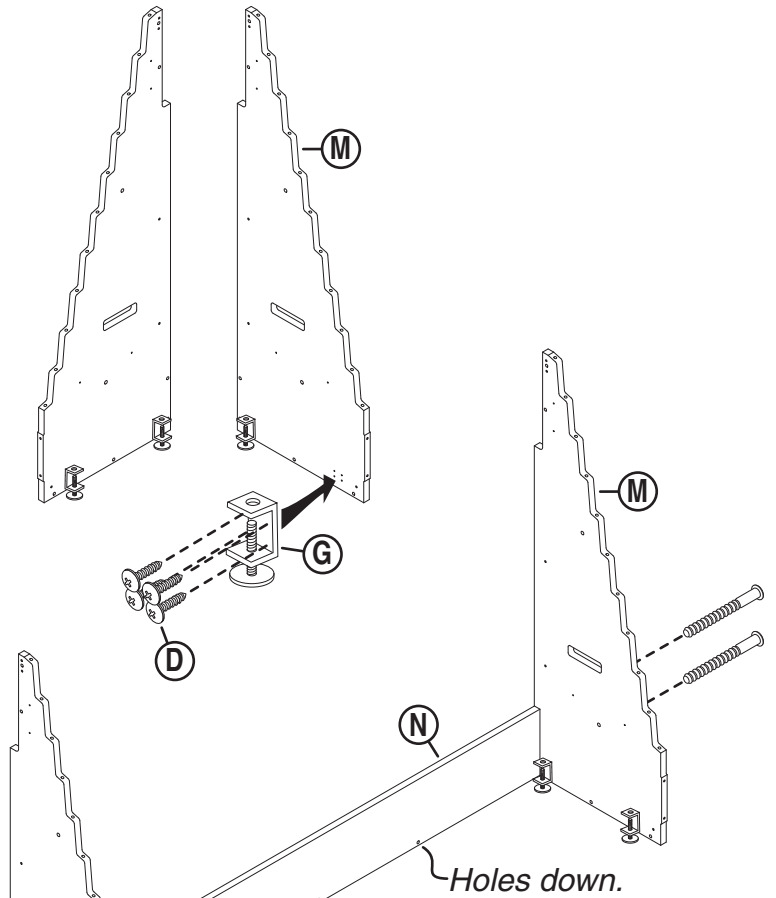

- 2 Use (4) Connector Bolts (A) to attach Lower Rear Panel (N) in between (2) Side Panels (M).

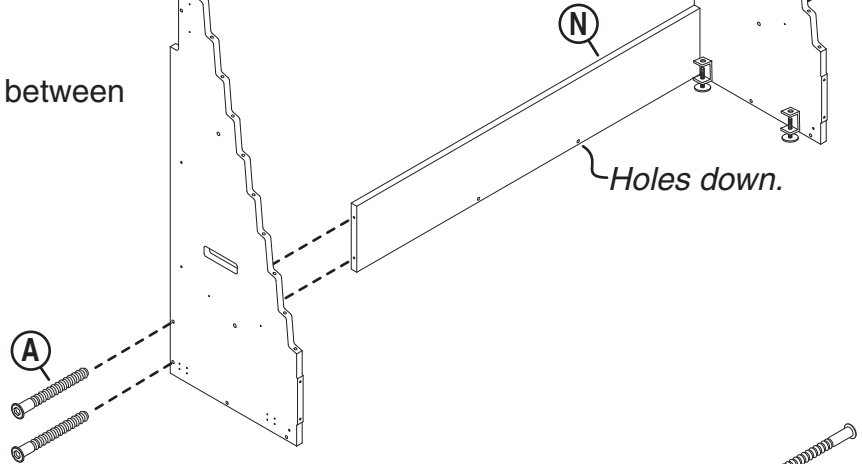

- 3 Use (4) Connector Bolts (A) to attach Upper Rear Panel (O) in between (2) side Panels (M).

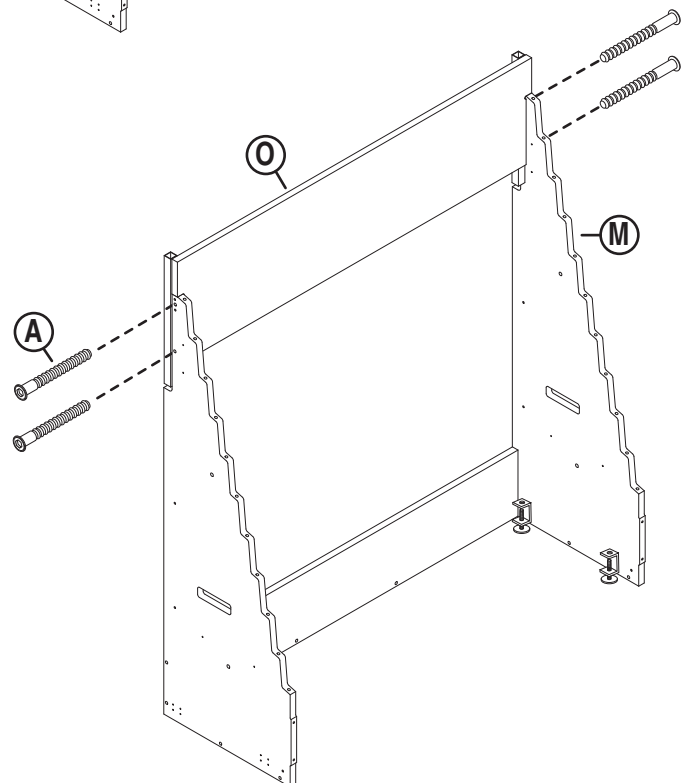

IMPORTANT NOTE:

*If you will be using
Optional Storage Base 8088
see instructions included with
that product and install it in
assembly before proceeding.*

ASSEMBLY

- 4** **NOTE:** *If using Optional Storage Base refer to instruction sheet 8088 for this step.*

Attach **Front Panel (P)** to assembly using **(4) Connector Bolts (A)**. After tightening **Connector Bolts (A)**, cover with **(4) Bolt Covers (W)**.

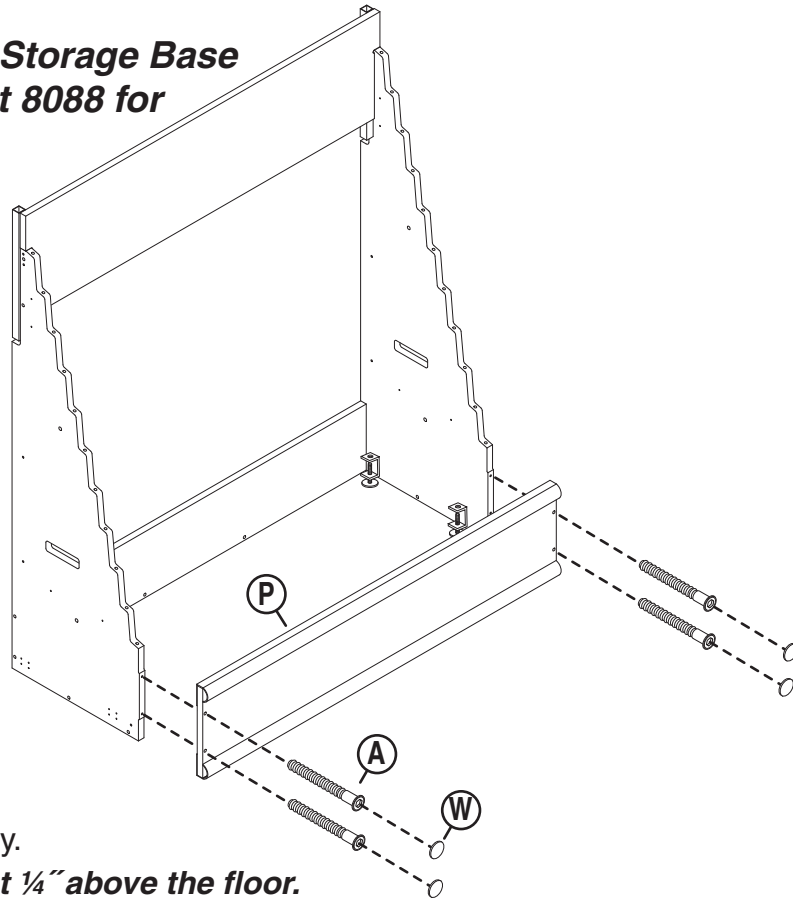

- 5** Position and level the assembly.

- *All points should be at least ¼" above the floor.*
- *If you are using Optional Storage Base 8088 you must allow clearance for the door to open without striking.*

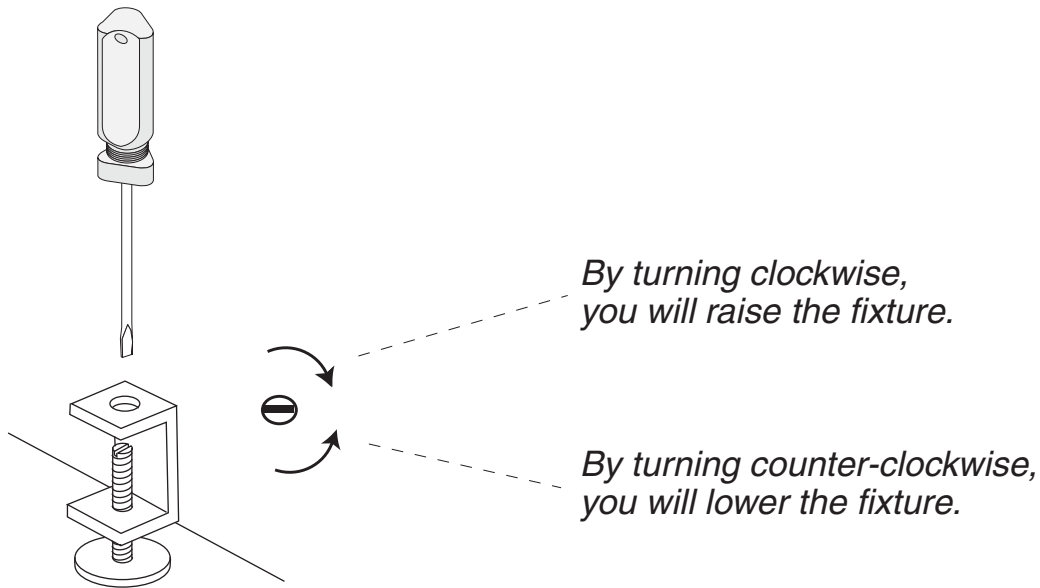

If you have any questions or need replacement parts, please call:

UPC Customer Service
1-800-859-7442

Design & Manufacture

ASSEMBLY

NOTE:

IF NOT BOLTING TWO FIXTURES TOGETHER, MOVE AHEAD TO STEP 7.

6 SIDE BY SIDE:

Attach two fixtures together using (2) Connector Bolts - Machine (K) and (2) Connector Nuts (J) as shown here.

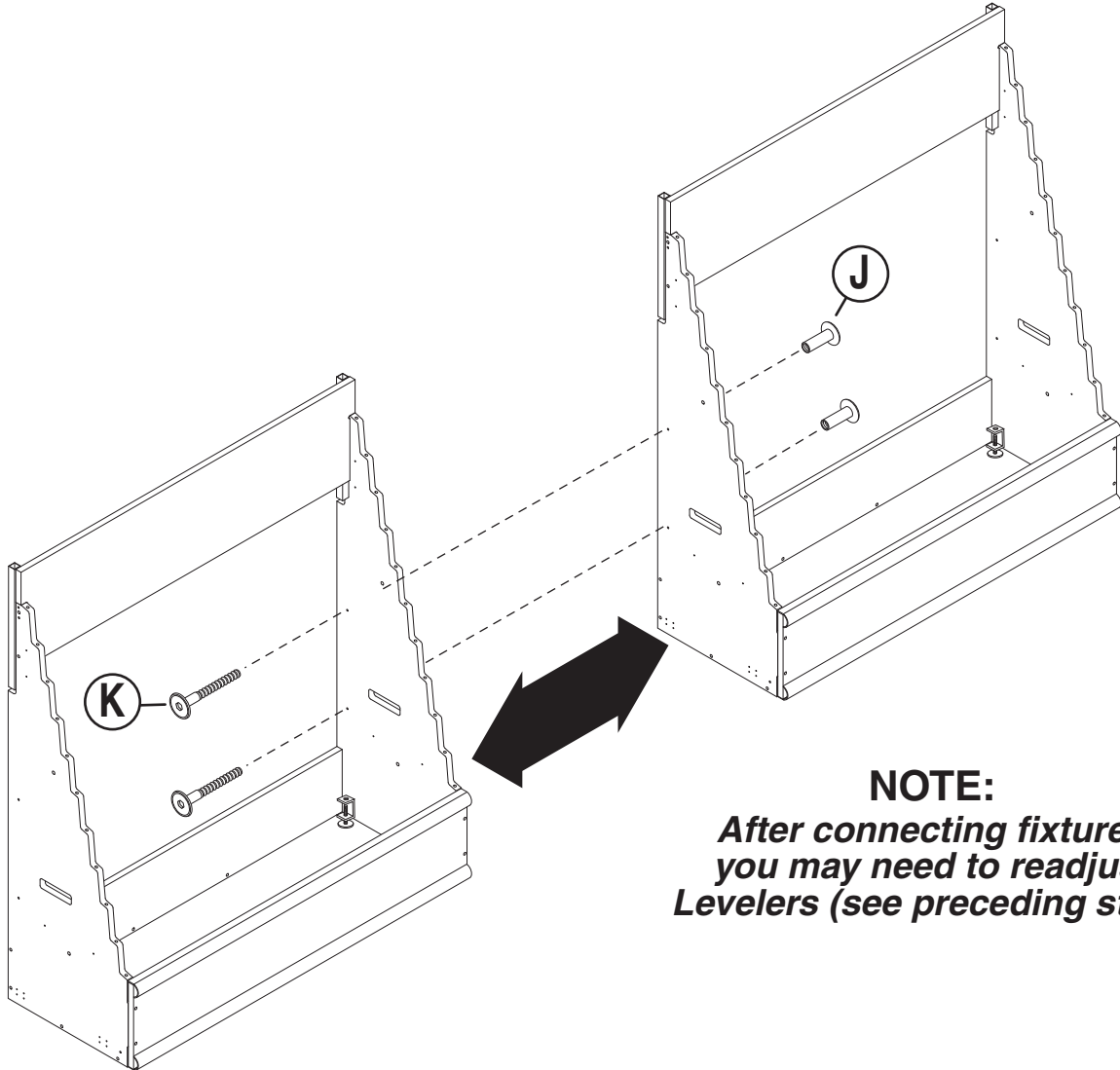

NOTE:

**After connecting fixtures
you may need to readjust
Levelers (see preceding step.)**

If you have any questions or need replacement parts, please call:
UPC Customer Service
1-800-859-7442

Design & Manufacture

ASSEMBLY

- 7** Peel off the masking and install the **Clear Rack (Q)** on the bottom using **(2) Push Pins (E)**.

See Push Pin installation tip below right.

Install **(10) White Racks (R)** using **Push Pins (E)**, working from lowest up.

See Rack installation note below left.

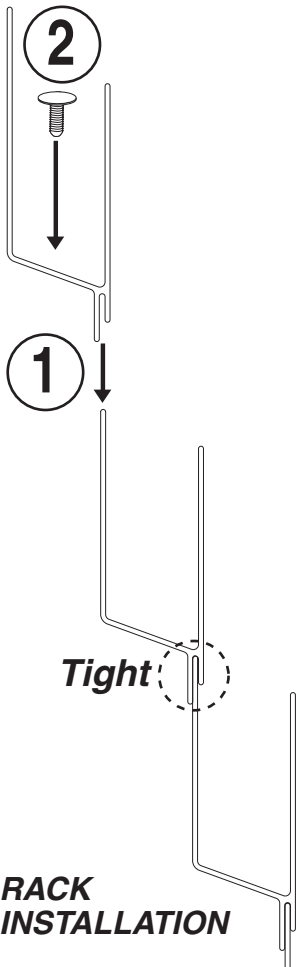
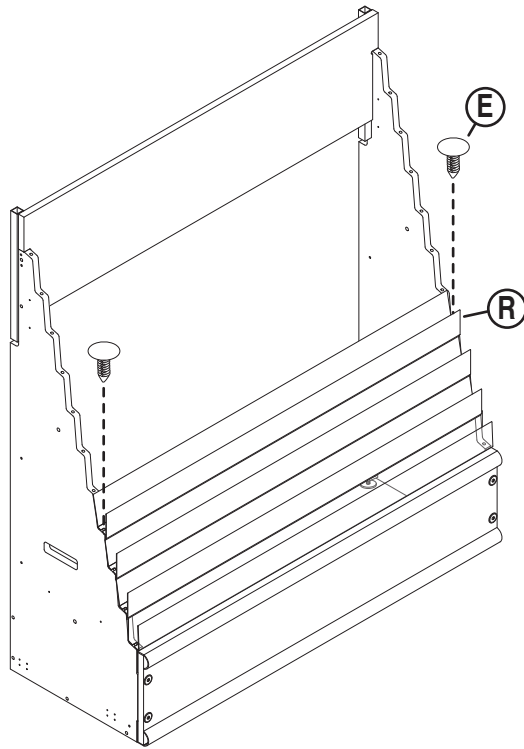
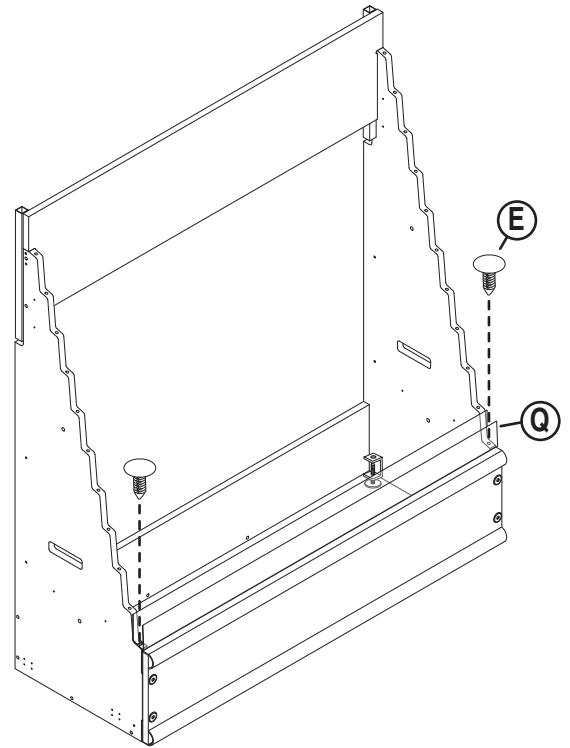

TIP: Many installers gently bend the rack open (below) and use the end of a screwdriver handle or hammer handle to press **Push Pins (E)** firmly into place.

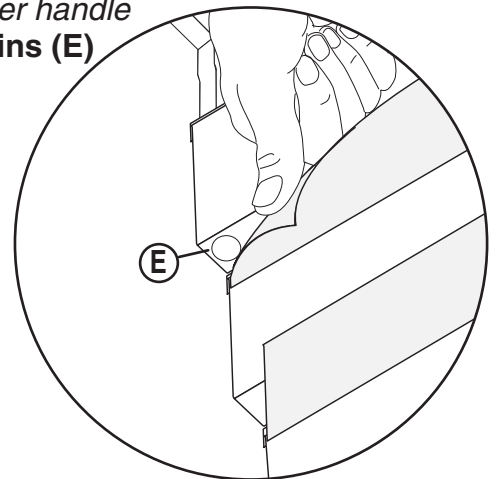

If you have any questions or need replacement parts, please call:

UPC Customer Service
1-800-859-7442

Design & Manufacture

ASSEMBLY

- 8 Insert (2) **Slotted Uprights (S)** in square holes in top of assembly and secure at desired height using (2) **Keys (F)** with indentations up.

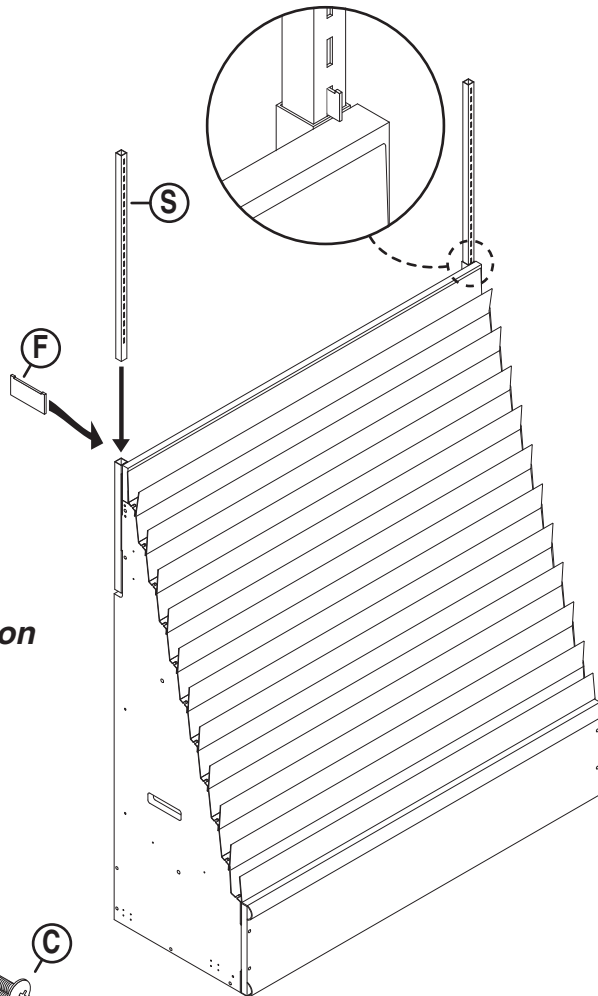

- 9 **NOTE: If using Optional Extender, refer to instruction sheet 80851 for this step.**

Attach **Left & Right Brackets (H&I)** to back of **Sign Track (T)** using (4) **Nuts (B)** and (4) **3/8" Trusshead Screws (C)**.

Be sure **Bracket teeth are facing down**. Hook **Sign Track Assembly** onto display.

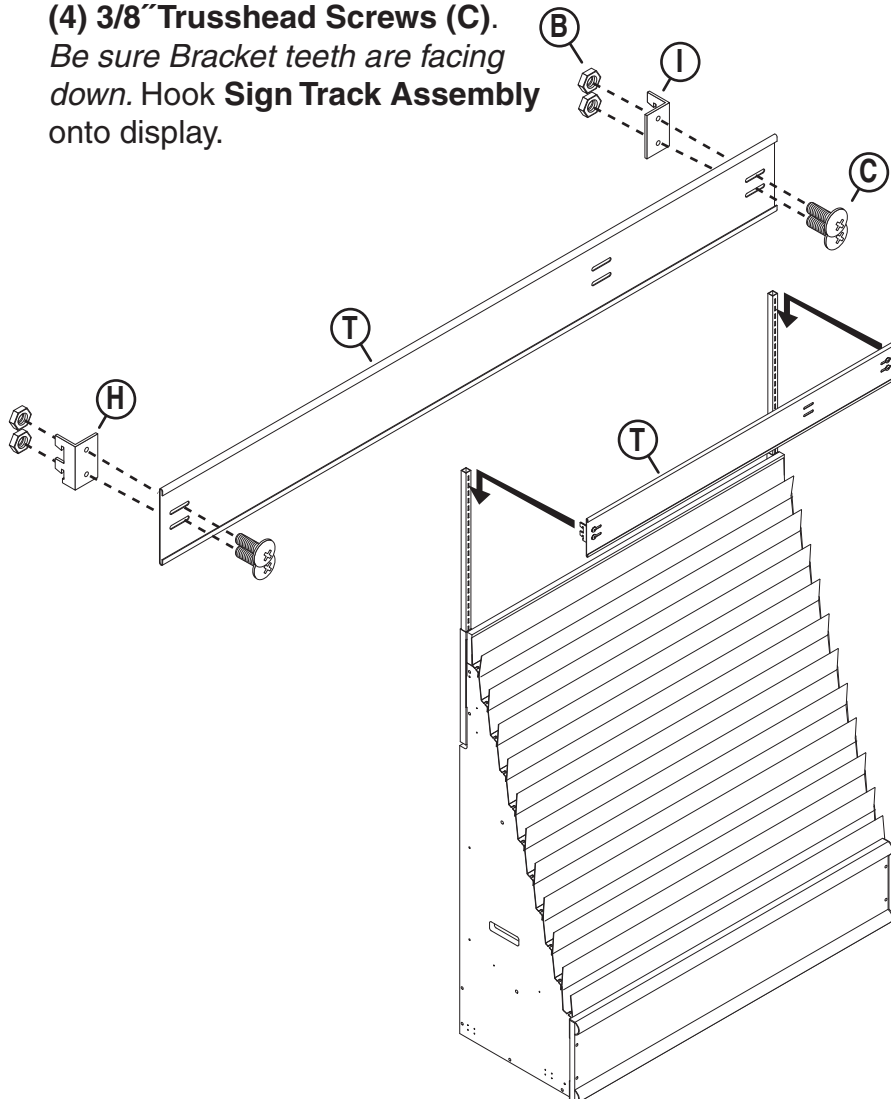

If you have any questions or need replacement parts, please call:
UPC Customer Service
1-800-859-7442

Design & Manufacture

ASSEMBLY

- 10** Install **(16) 3-Tier Divider Strips (U)** in the top 6 racks.
Install **(8) 5-Tier Divider Strips (V)** in bottom 5 racks.

