

ASSEMBLY INSTRUCTIONS

Thank you for your purchase of one of many fine products designed & manufactured by UPC. We have made every effort to make your assembly easy, clear & hassle free. For more information or if you have any questions contact customer service at 1-800-859-7442.

PARTS BAG UPC 8088 11 Tier 4' Storage Base

PART	Quantity	Reference
Connector Bolt	6	A
Screw	4	B
Hinge	2	C
Cap	4	D
Allen Wrench	1	E

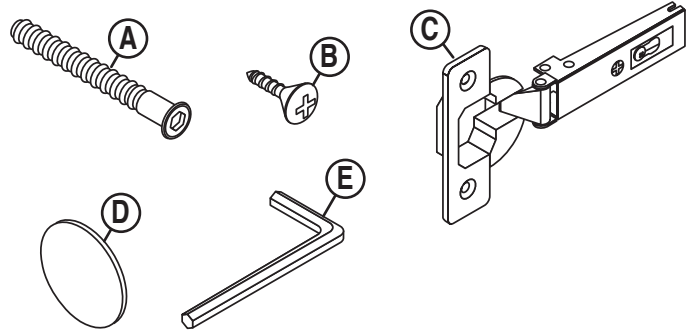

TOOLS REQUIRED: #2 Phillips Screwdriver

This part used with UPC 8089

PARTS LIST

PART	Quantity	Reference
Base	1	F

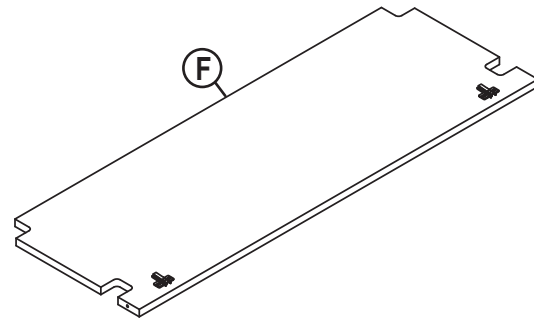

ASSEMBLY

- 1 Attach **Base (F)** to assembly using (6) **Connector Bolts (A)**.

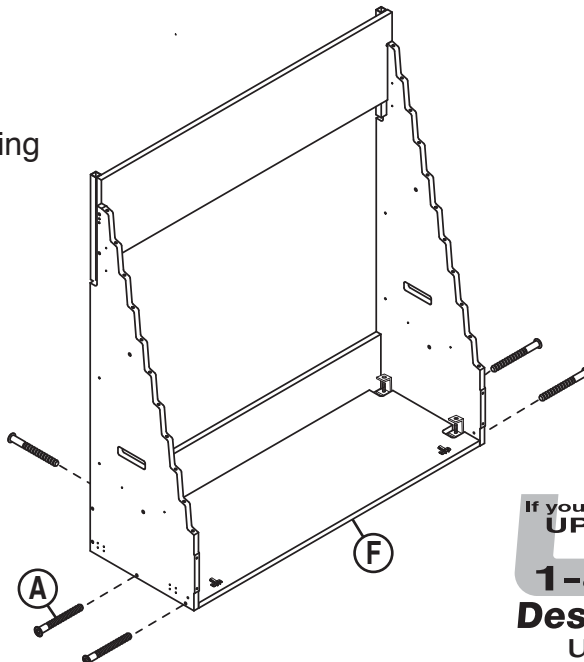

If you have any questions please call:
UPC Customer Service
1-800-859-7442
Design & Manufacture
upcdisplays.com

ASSEMBLY

- 2 Attach (2) Hinges (C) to Front Panel (P) from 8089 using (4) Screws (B).

Attach Front Panel (P) to assembly by snapping hinges into hinge plates attached to Base (F).

See *DETAIL* bottom right.

Peel masking paper and attach (4) Caps (D) to cover screw holes in front side of Front Panel (P) from 8089.

Continue assembling full fixture according to directions included with 8089.

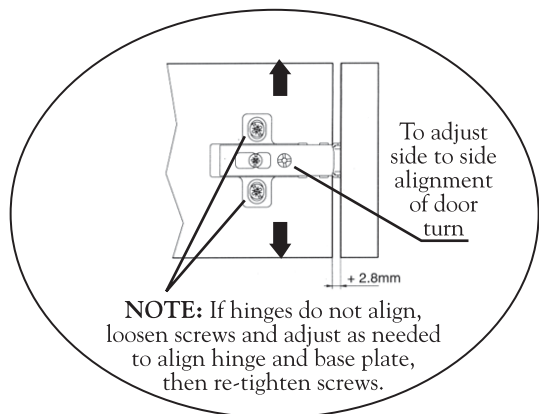
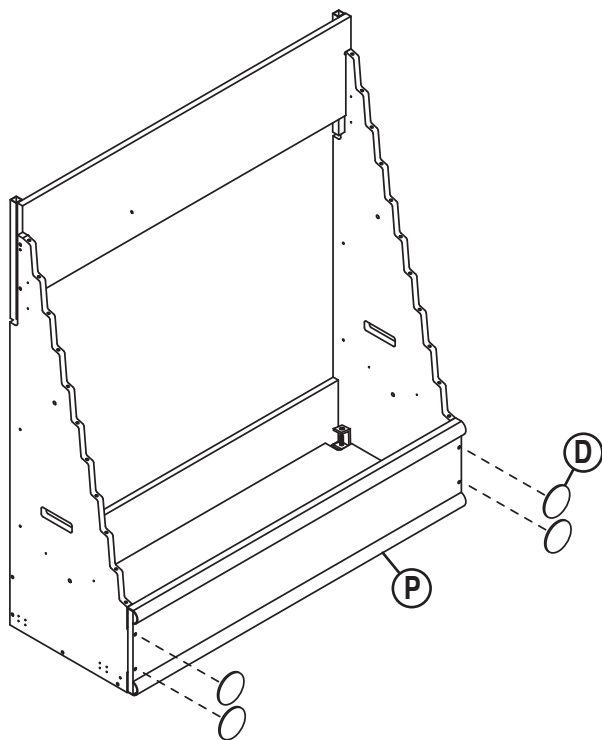
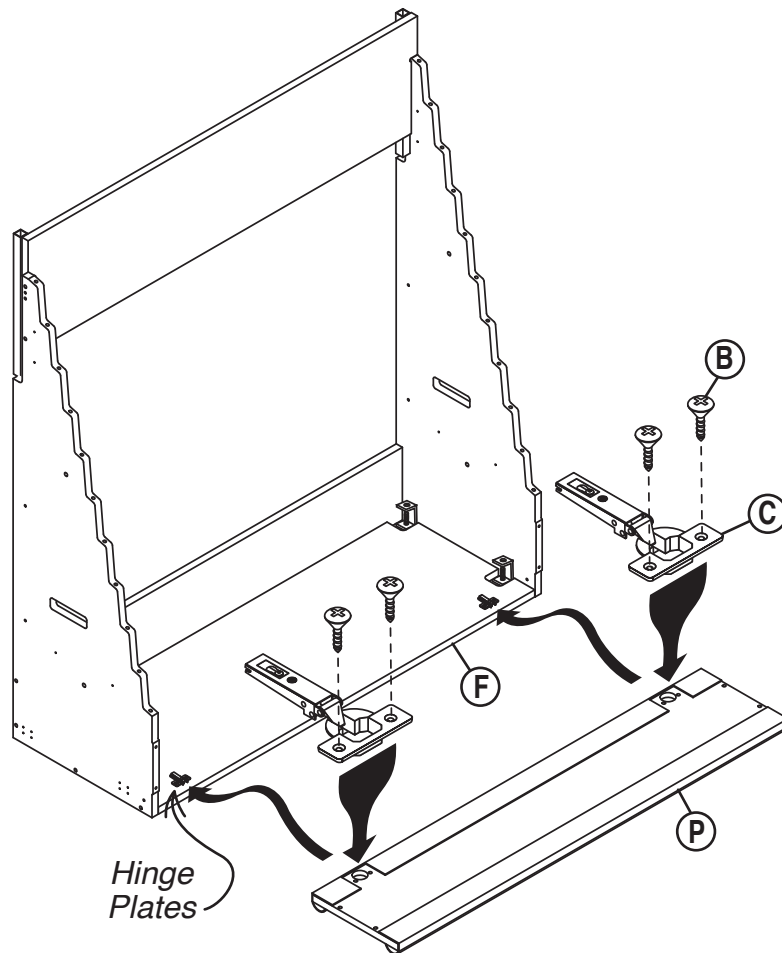

HINGE ADJUSTMENT

HINGE ATTACHMENT DETAIL

- 1) Place hinge in slightly inclined position and slide front hook under baseplate hook.
- 2) Push hinge end with finger and snap hinge into mounting plate.