

PARTS BAG

UPC 8087

11 Tier 4' Back Panel

PART	Quantity	Reference
Screw	12 (2 extra)	A

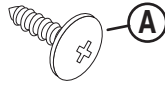

TOOLS REQUIRED: #2 Phillips Screwdriver

PARTS

PART	Quantity	Reference
Upper Back Panel	1	B
Lower Back Panel	1	C

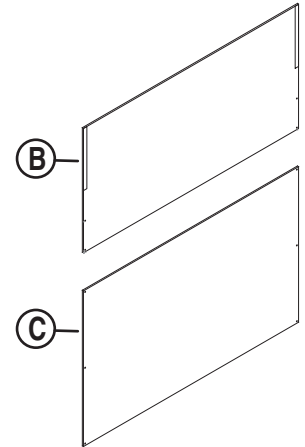

ASSEMBLY

1 Peel masking from double stick tape on **Upper Back Panel (B)**.

Orient Panel with tape toward top, align top of Panel with top of Assembly, and attach **Upper Back Panel (B)** to the back of the Assembly using (4) **Screws (A)**.

Press upper sides against Assembly to adhere tape.

Install **Lower Back Panel (C)** to the back of unit using (6) **Screws (A)**.

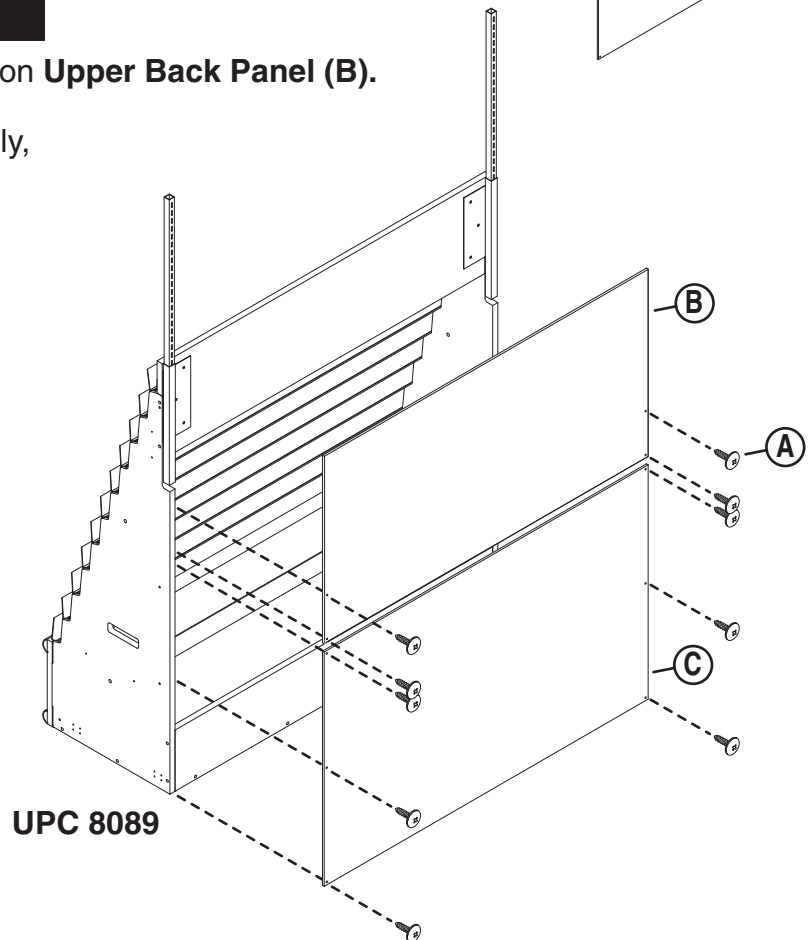

If you have any questions or need replacement parts, please call:

UPC Customer Service
1-800-859-7442

Design & Manufacture