

**PARTS BAG** **4842S, 4843S** **Strip Sign Holder**

PART	Quantity	Reference
Screw	4	A
Hex Nut	4	B
Right Bracket	1	C
Left Bracket	1	D
Slotted Upright Keys	2	E

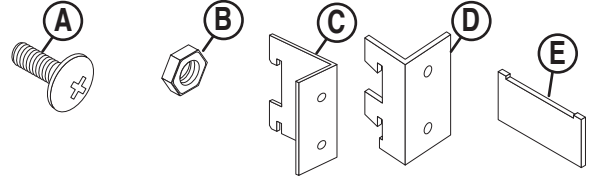

**PARTS LIST**

PART	Quantity	Reference
Strip Sign	1	F
Slotted Uprights	2	G

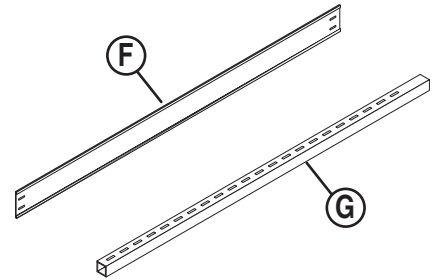

**ASSEMBLY**

**1** Place the **Slotted Upright Keys (E)** into the desired slots making sure the notches face up.



NOTCHES



**2**

Hold the **Slotted Upright Keys (E)** in place and slide the **Slotted Uprights (G)** into the fixture until they rest on the **Slotted Upright Keys (E)**.

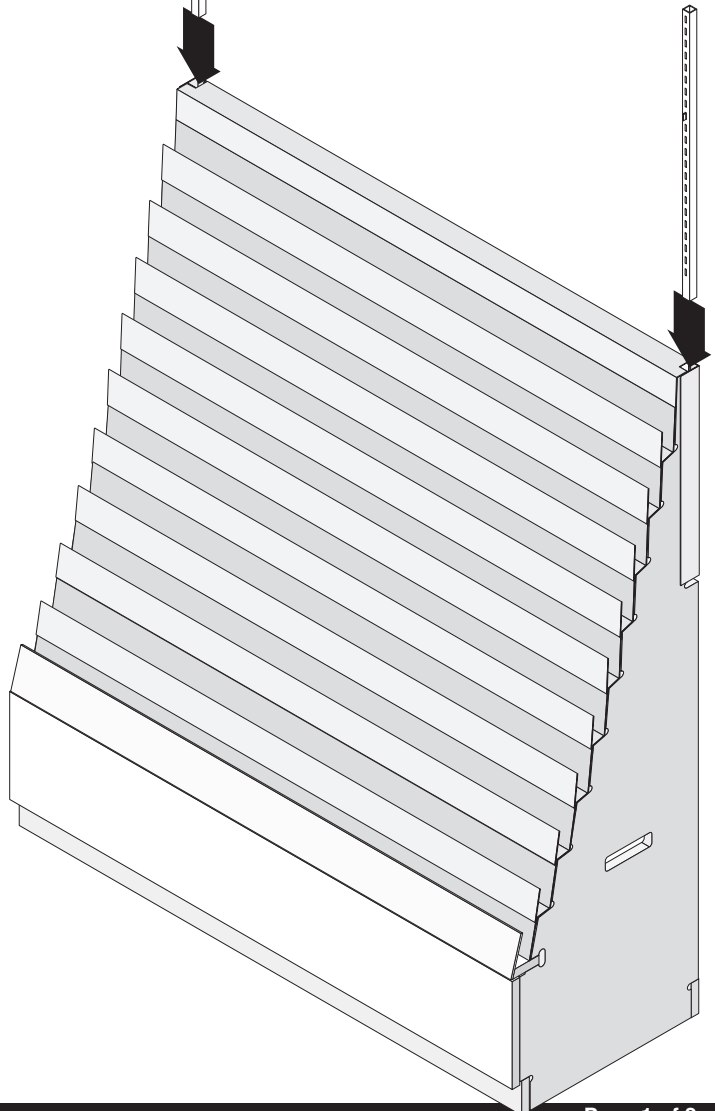

If you have any questions or need replacement parts, please call:  
**UPC Customer Service**  
 1-800-859-7442  
**Design & Manufacture**

If you have any questions or need replacement parts, please call:  
**UPC Customer Service**  
1-800-859-7442

**Design & Manufacture**

## ASSEMBLY

- 3** Mount **Left and Right Brackets (C & D)** to **Strip Sign (F)** using **Screw (A)** and **Hex Nut (B)**.

Hang **Strip Sign (F)** assembly on **Slotted Uprights (G)** using the **Right and Left Bracket (C & D)** hooks.

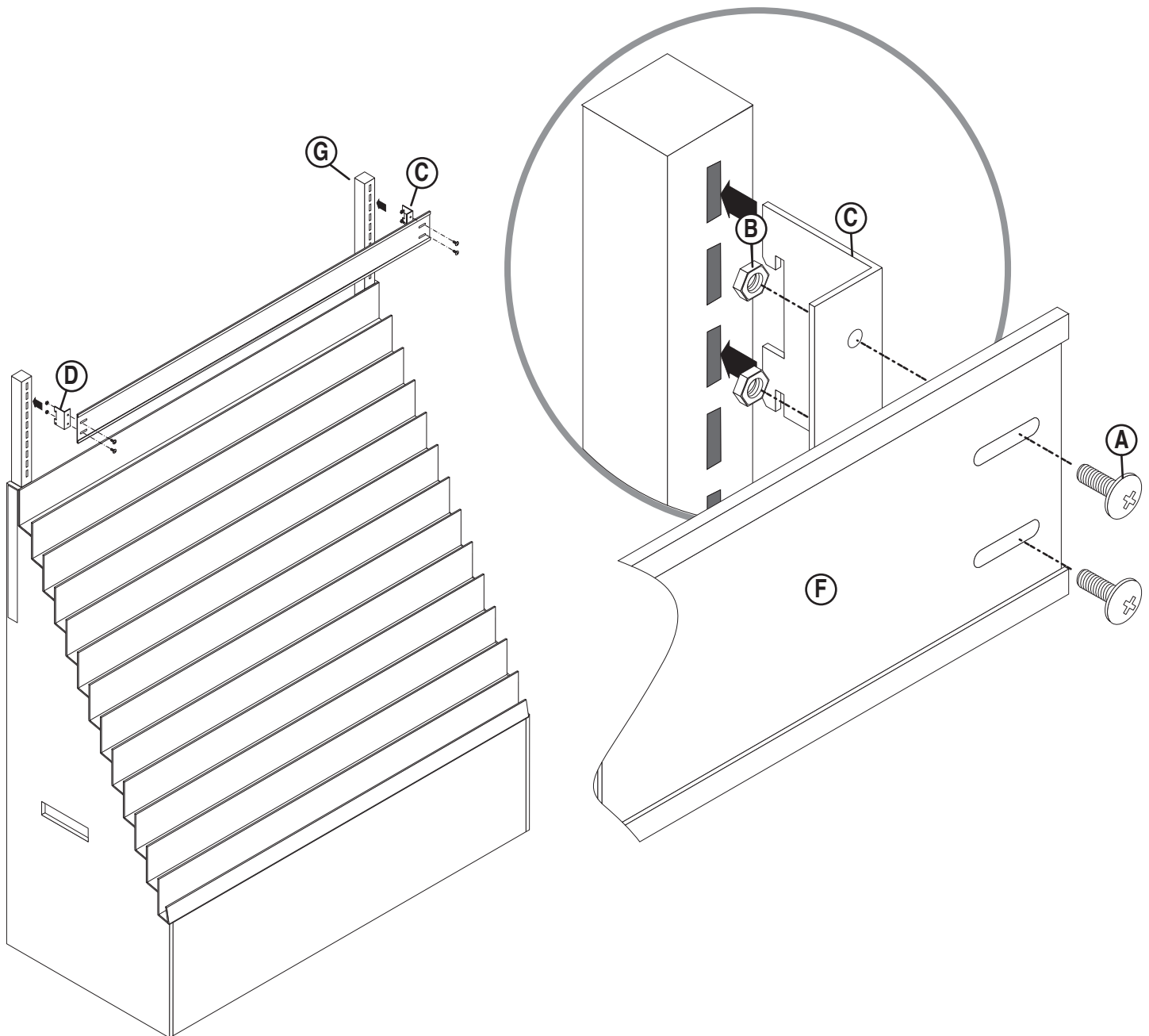

If you have any questions or need replacement parts, please call:  
**UPC Customer Service**  
1-800-859-7442

**Design & Manufacture**