

PARTS BAG **UPC #4559** **24 Pocket Spinner**

PART	Quantity	Reference
#8-32 x 3/8" Screws	4	A
Screw Posts	4	B
Ratchet Rivets	2	C
Header Clip	2	D

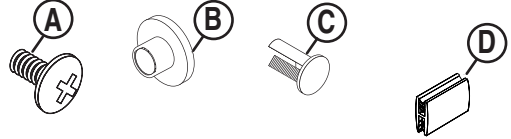

PARTS LIST

PART	Quantity	Reference
Pockets	24	E
Side Panels	2	F
Spinner	1	G
Base	1	H

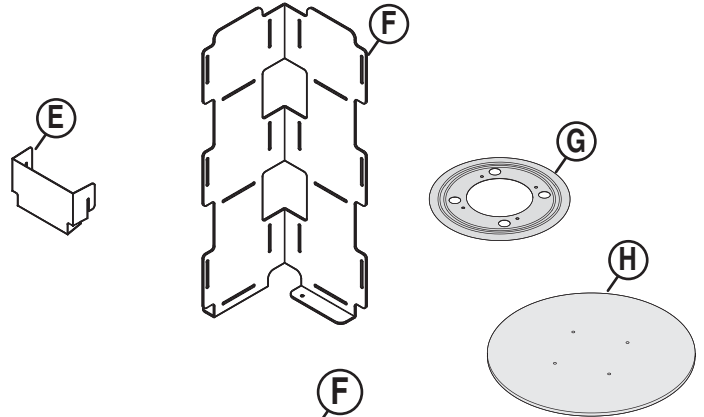

ASSEMBLY

- 1 Attach (2) **Side Panels (F)** to **Base (H)** and to **Spinner (G)** with (4) **#8-32 x 3/8" Screws (A)** and (4) **Screw Posts (B)**.

Connect both **Side Panels (F)** with (2) **Ratchet Rivets (C)**, through holes at top of **Side Panels (F)**.

Note: Side Panels (F) should form the shape of an "X".

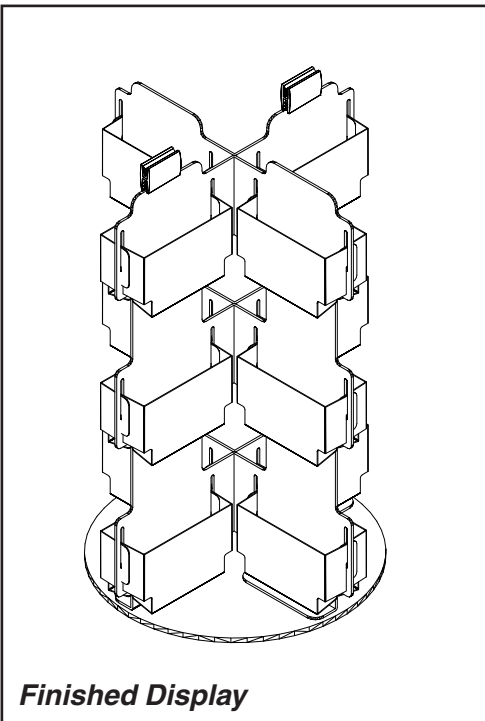
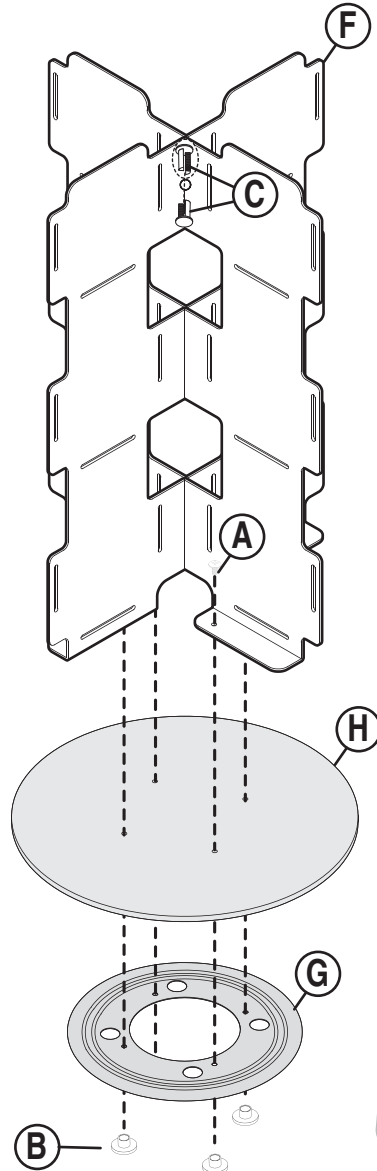

If you have any questions or need replacement parts, please call:
UPC Customer Service
 1-800-859-7442
Design & Manufacture

If you have any questions or need replacement parts, please call:

UPC Customer Service
1-800-859-7442

Design & Manufacture

ASSEMBLY

- 2 Attach **Pockets (E)** by hooking the tabs into the vertical slots in the **Side Panels (F)**.

Lock bottom tongue of **Pockets (E)** into the horizontal slots on the **Side Panels (F)**.

Each slot holds (2) **Pockets (E)**, one on each side of the **Side Panel (F)**.

Attach (2) **Header Clips (D)** where needed.

