

ASSEMBLY INSTRUCTIONS

PARTS LIST UPC#3820A 72-PKT.Spinner

PART	Quantity	Reference
Push Pin	13 (1 extra)	A
Trusshead Screw	6	B
Header	1	C

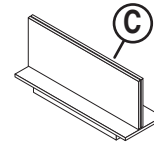
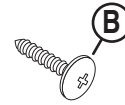
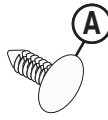

TOOLS REQUIRED: #2 Phillips Screwdriver

PARTS LIST

PART	Quantity	Reference
Tower Panel	3	D
Tower Helper	2	E
Top Cap	1	F
Base	1	G
Racks	72	H

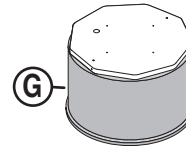
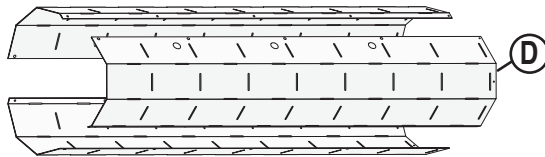
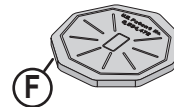
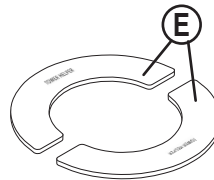

ASSEMBLY

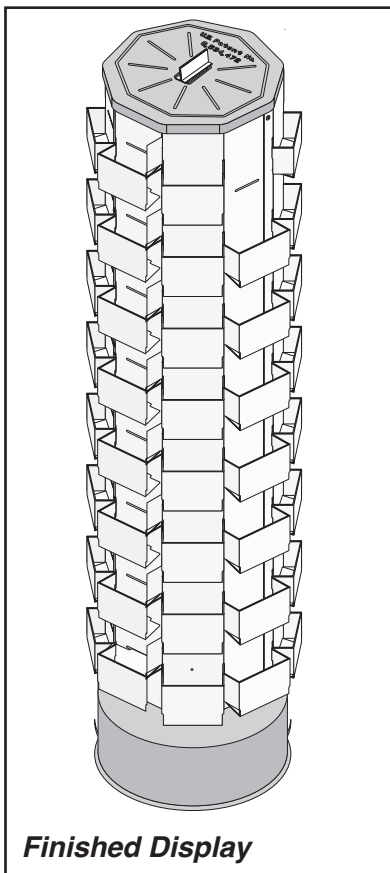

- 1 Remove (2) screws from **Base (G)** and discard before beginning assembly.

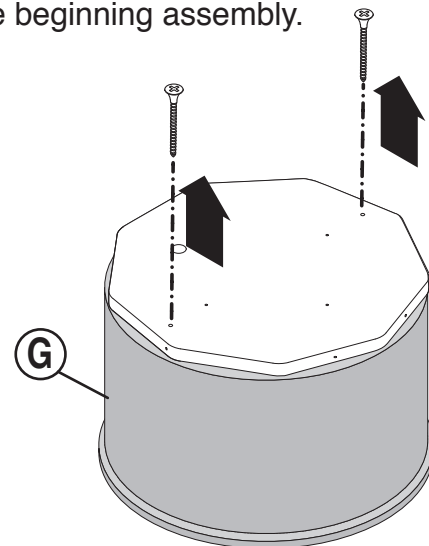

If you have any questions or need replacement parts, please call:
UPC Customer Service
 1-800-859-7442
Design & Manufacture

ASSEMBLY

- 2** **A.** Peel protective masking off **Tower Panels (D)** before assembly.
- B.** Overlap each **Tower Panel (D)** so the large hole of facet lies outside the small hole of adjacent panel. (see figure *RIGHT*)
- C.** Use Large Finger Holes (see figure *RIGHT*) to hold **Tower Panels (D)** tightly together while installing **Push Pins (A)**.
- D.** Join (3) **Tower Panels (D)** together using (12) **Push Pins (A)**. (see figure *BELOW*)

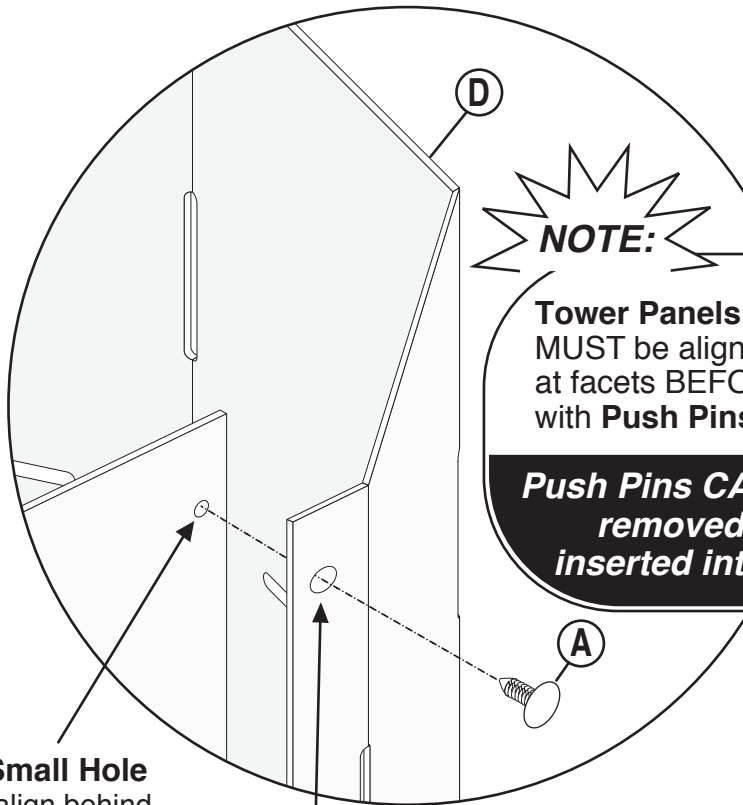
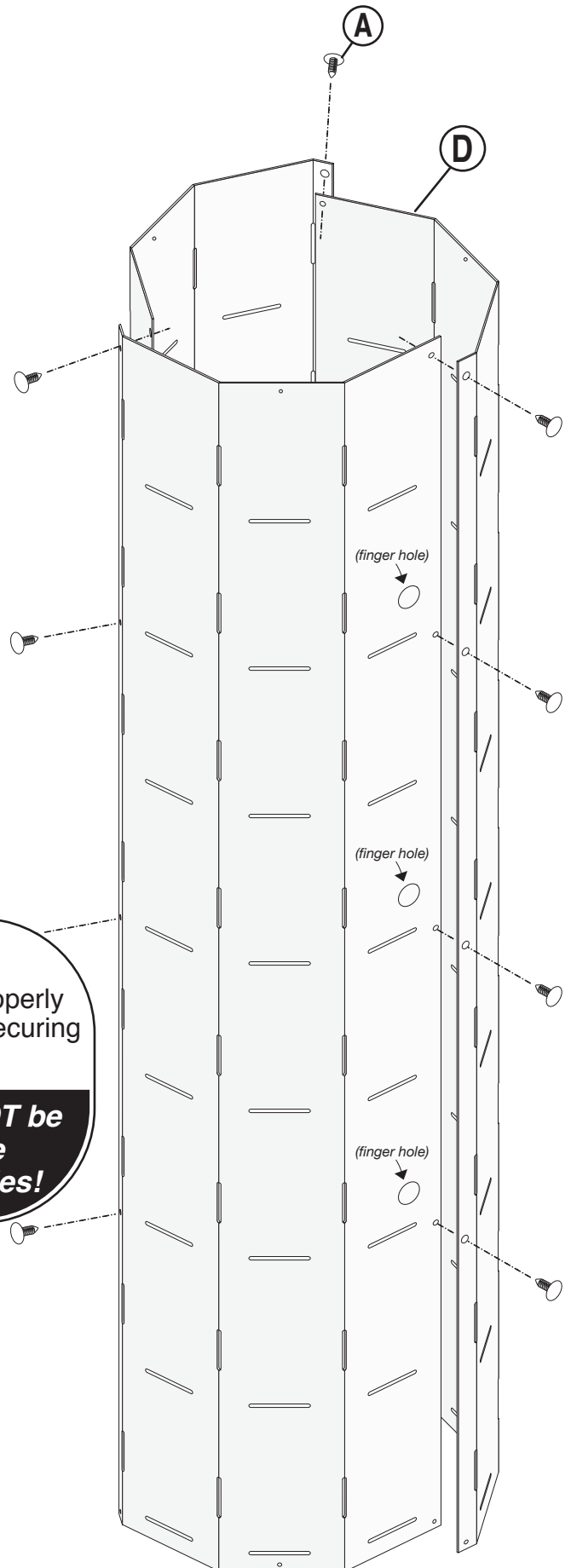

NOTE:
Tower Panels (D) MUST be aligned properly at facets BEFORE securing with Push Pins (A).
Push Pins CANNOT be removed once inserted into holes!

Small Hole
(align behind Large Hole)

Facet with Large Hole
(align in front of Small Hole)

ASSEMBLY

- 3 This step will hold **Tower Panel Assembly (D)** up for installation to **Base (G)**. Insert (2) **Tower Helpers (E)** under spinner plate on base, as shown below.

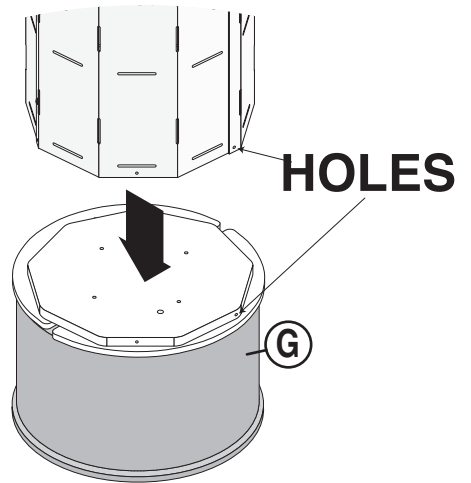
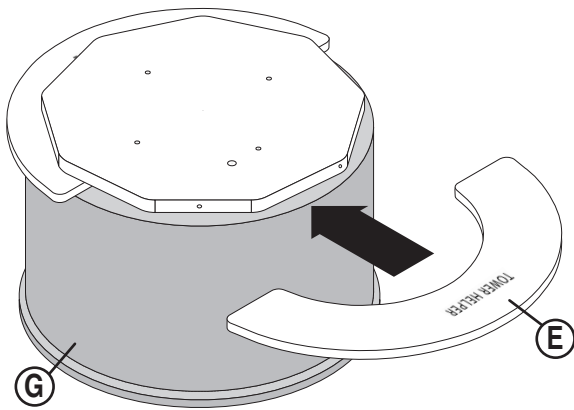

- 4 Align corresponding holes and set the **Tower Panel Assembly (D)** onto the **Base (G)**.

- 5 Secure **Tower Panel Assembly (D)** to Base Assembly at middle holes of Tower Panel Assembly. Attach Tower Panels to Spinner Plate edge with (3) **Trusshead Screws (B)**. **DO NOT** tighten completely!

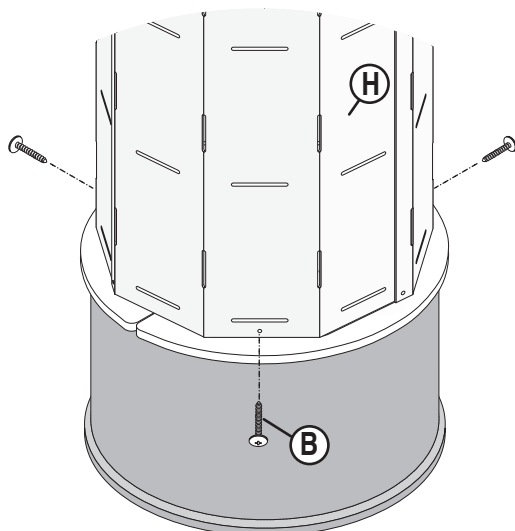

- 6 Continue to secure **Tower Panel Assembly (D)** to Base Assembly at corner holes of Tower Panel Assembly. Attach panels to Spinner Plate edge with (3) **Trusshead Screws (B)**. Tighten all (6) securely.

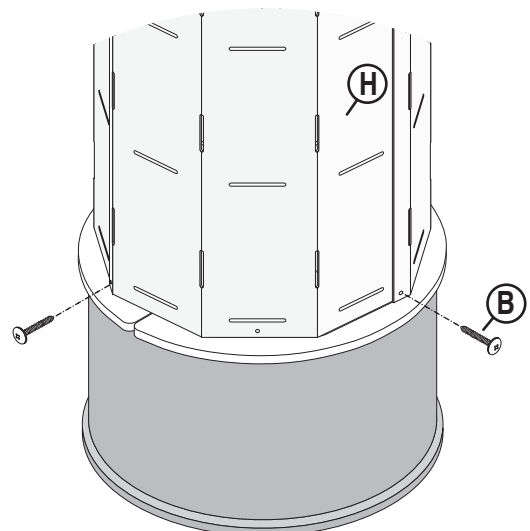

ASSEMBLY

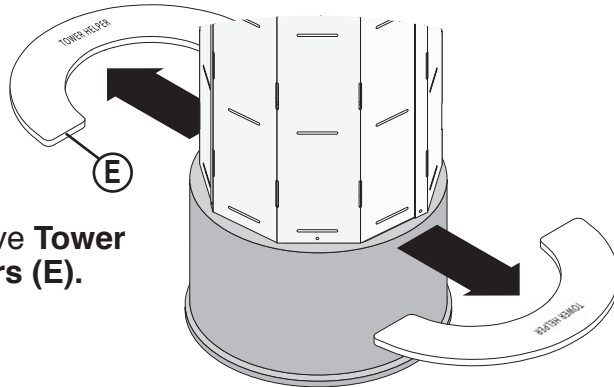

7 Remove **Tower Helpers (E)**.

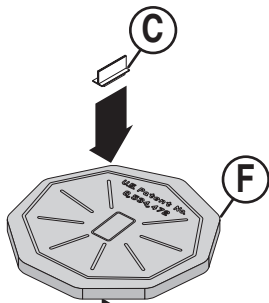

8 Peel masking off of **Header Clip (C)** and secure to the center of the **Top Cap (F)**.

Attach **Top Cap (F)** to the top of the **Tower Panel Assembly (D)**.

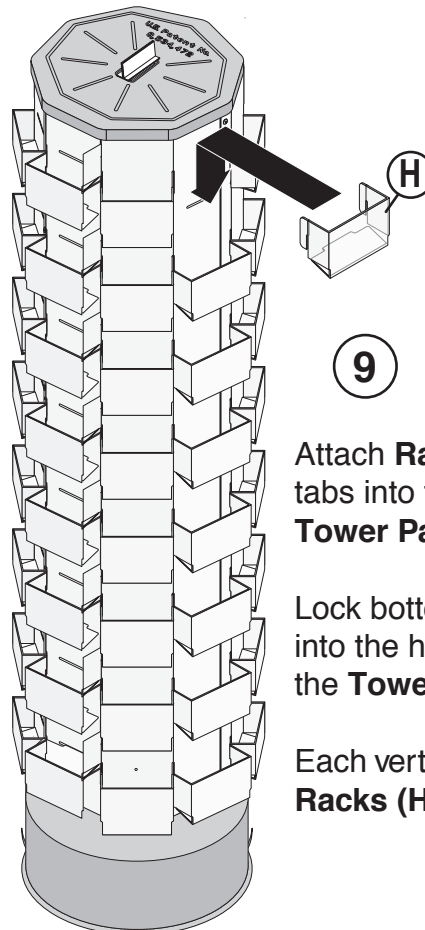
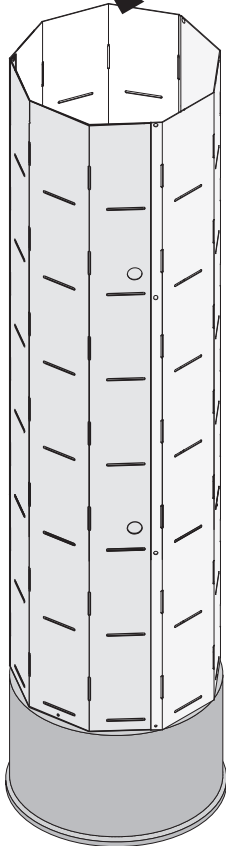

9 Attach **Racks (H)** by hooking the tabs into the vertical slots in the **Tower Panels (D)**.

Lock bottom tongue of **Racks (H)** into the horizontal slots on the **Tower Panels (D)**.

Each vertical slot holds two **Racks (H)** side-by-side.