

ASSEMBLY INSTRUCTIONS

PARTS BAG

UPC #3637A

36" 2-Tier PETG Rack with 2/3 Exposure

PART	Quantity	Reference
Screw Posts	3	A
Slatwall Adapters	3	B
Hex Nuts	3	C
Wall Toggles	3	D
Phillips Head Screws	3	E
Card Clips	12	F

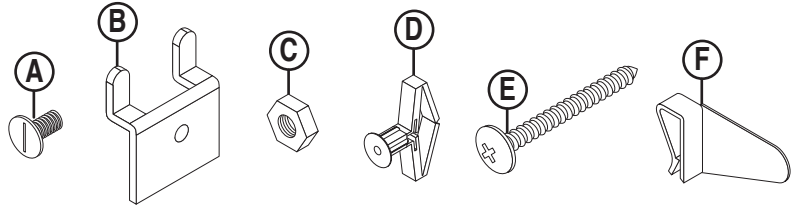

**TOOLS REQUIRED: Flathead Screwdriver (Slatwall)
Drill with 3/8" Drywall Bit & Phillips Screwdriver (Drywall)**

PARTS LIST

PART	Quantity	Reference
Rack	1	G

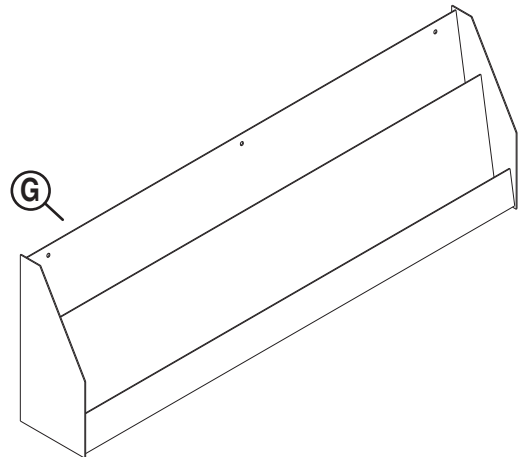

Slatwall Assembly

NOTE: Assemble for EITHER Slatwall or Drywall, not both.

- Align hole in **Slatwall Adapter (B)** with back side of hole in **Rack (G)**. Prongs extend back toward Slatwall and up. Attach using **Screw Post (A)** from front and **Hex Nut (C)** on back.

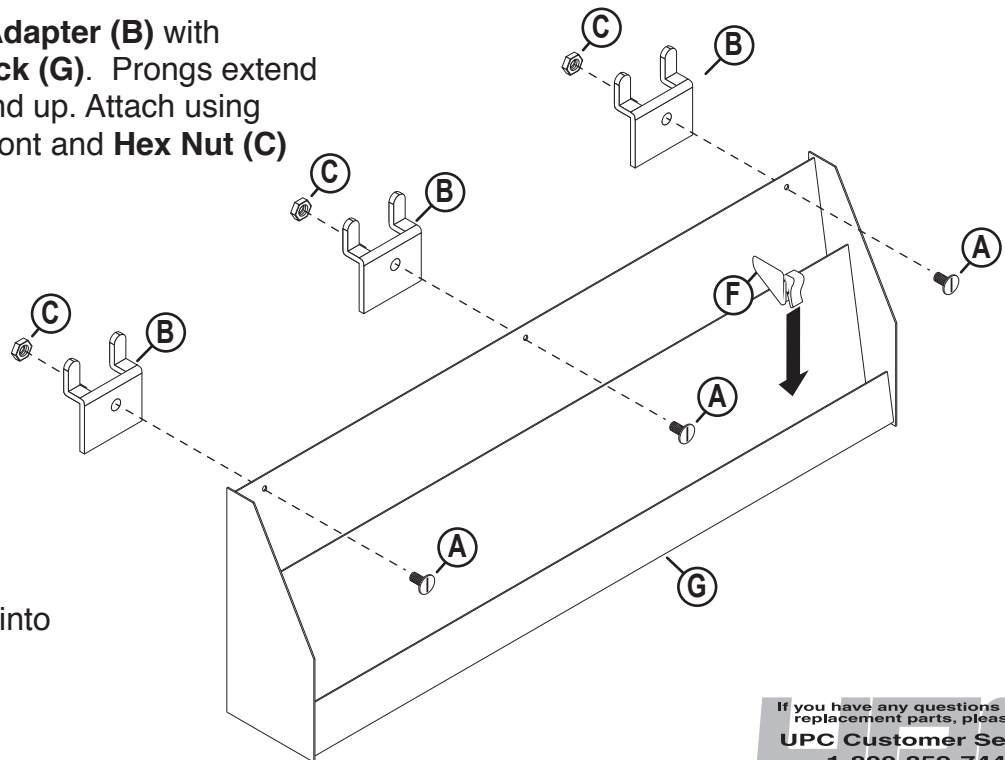

- Insert **Card Clips (F)** into **Rack (G)**.

If you have any questions or need replacement parts, please call:

UPC Customer Service
1-800-859-7442

Design & Manufacture

Drywall Assembly

NOTE: Assemble for EITHER Slatwall or Drywall, not both.

- 1 Determine position on wall and drill 3/8" hole. Squeeze **Wall Toggler (D)** flat and insert into hole. Tap flange flush with wall.

- 2 Place **Rack (G)** against Toggler and insert **Phillips Head Screw (E)**, tightening until secure.

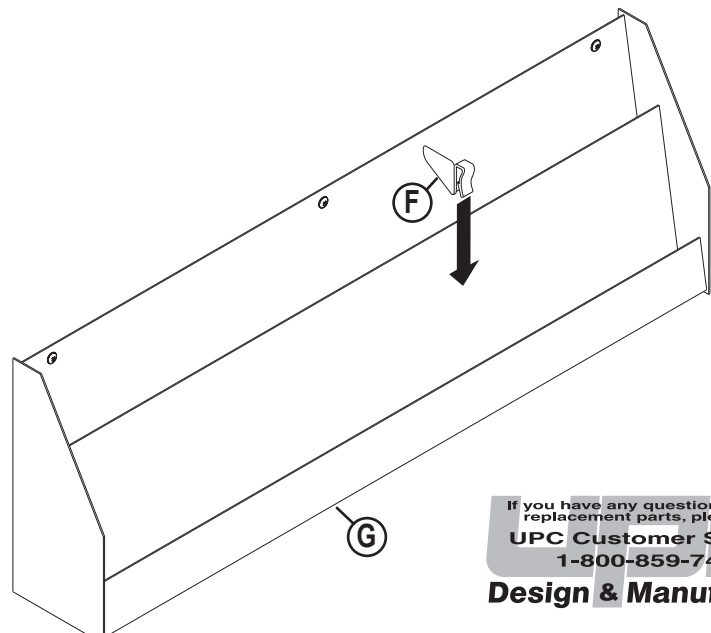
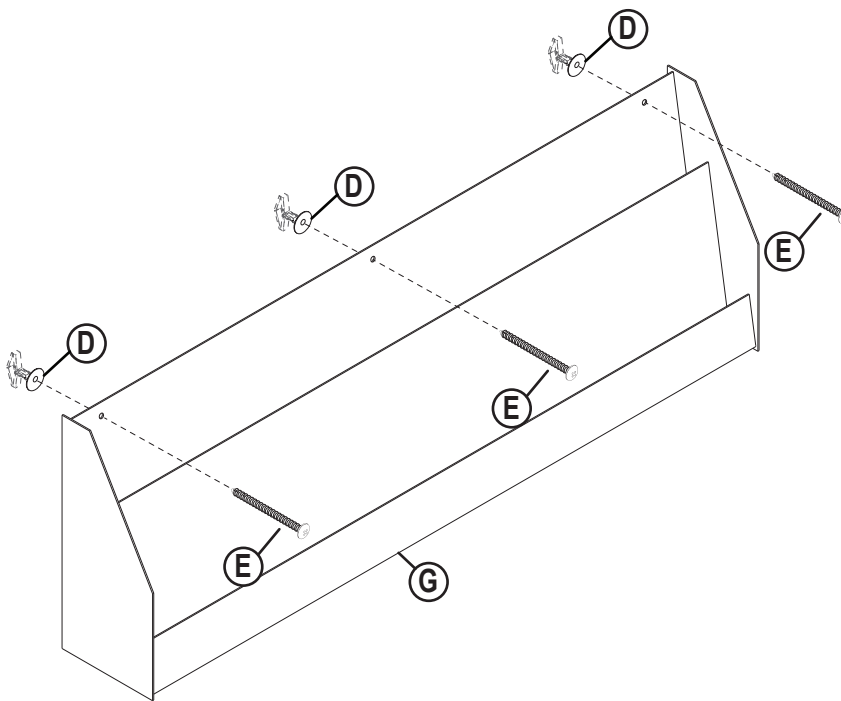
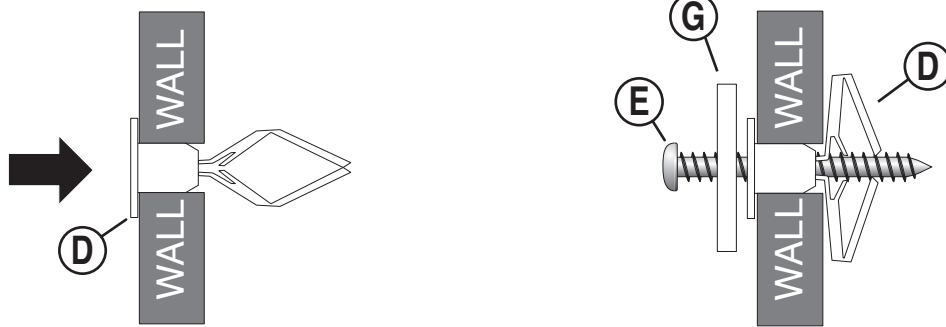

- 3 Insert **Card Clips (F)** into **Rack (G)**.

If you have any questions or need replacement parts, please call:
UPC Customer Service
1-800-859-7442

Design & Manufacture