

Thank you for your purchase of one of many fine products designed & manufactured by UPC. We have made every effort to make your assembly easy, clear & hassle free. For more information or if you have any questions contact customer service at 1-800-859-7442.

**PARTS BAG      UPC 3283      Single Sided 13 Tier Colossal**

PART	Quantity	Reference
Connector Bolt	19 (1 extra)	A
Screw	4	B
Push Pin	24	C
Threaded Stud	1	D
Allen Wrench	1	E
Connector Bolt Cover	19 (1 extra)	F
Card Clip	112	O

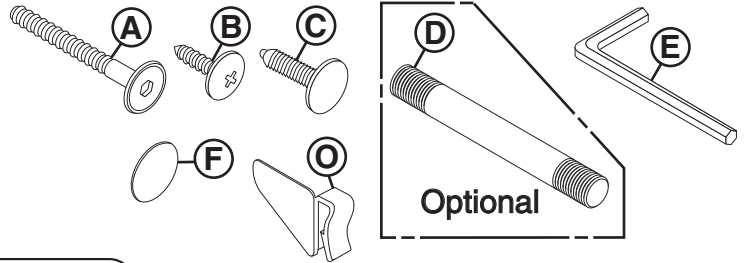

**OTHER TOOLS REQUIRED: #2 Phillips Screwdriver**

**PARTS LIST**

PART	Quantity	Reference
Sides	2	G
Bottom Center Panel	1	H
Top Center Panel	1	I
Kicks	1	J
Bottom Plates	1	K
Clear Racks	2	L
White Racks	11	M
Sign Holder (32784, 32785, 32788)	1	N

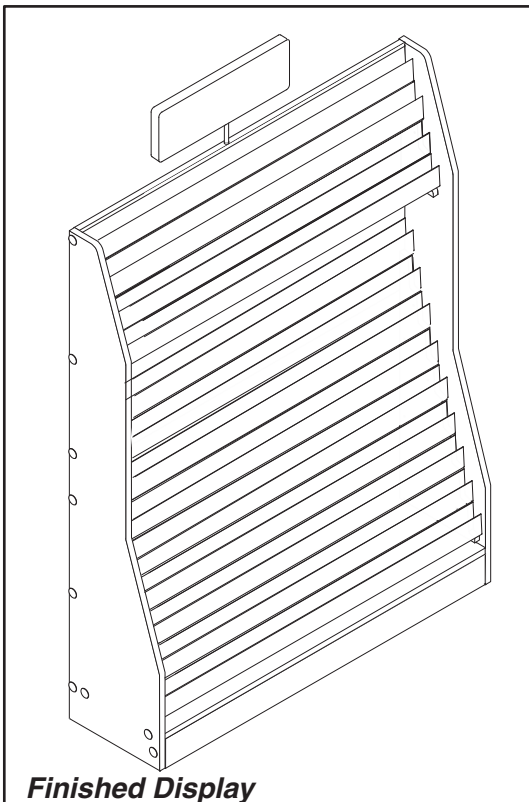
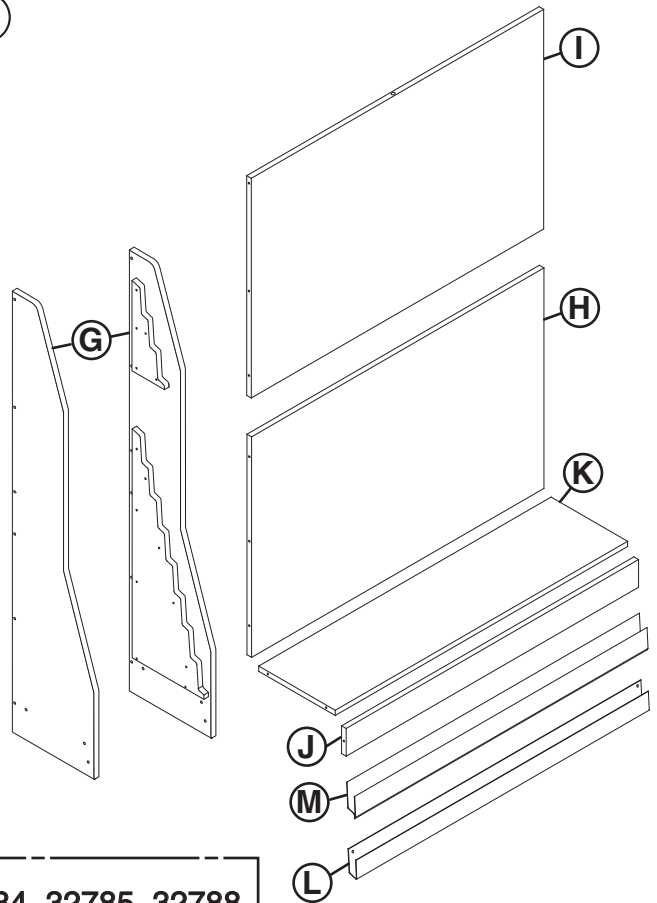

**Finished Display**

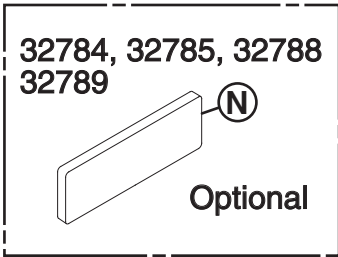

If you have any questions please call:  
**UPC**  
UPC Customer Service  
**1-800-859-7442**  
Design & Manufacture  
upcdisplays.com

## ASSEMBLY

Attach **Bottom Center Panel (H)** (has no finished edges, end holes closer to top edge) to **Side (G)** using **(3) Connector Bolts (A)**.

Attach **Top Center Panel (I)** (with finished edge up) to **Side (G)** using **(3) Connector Bolts (A)**.

Attach **(6) Connector Bolt Covers (F)**.

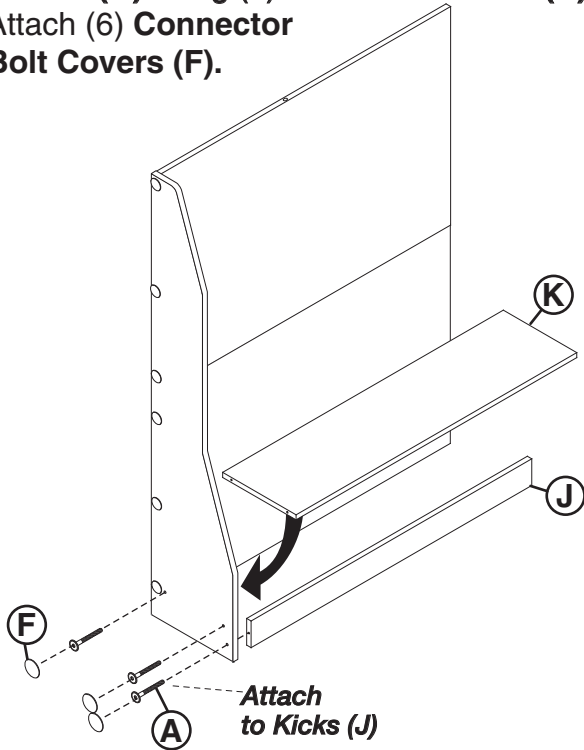
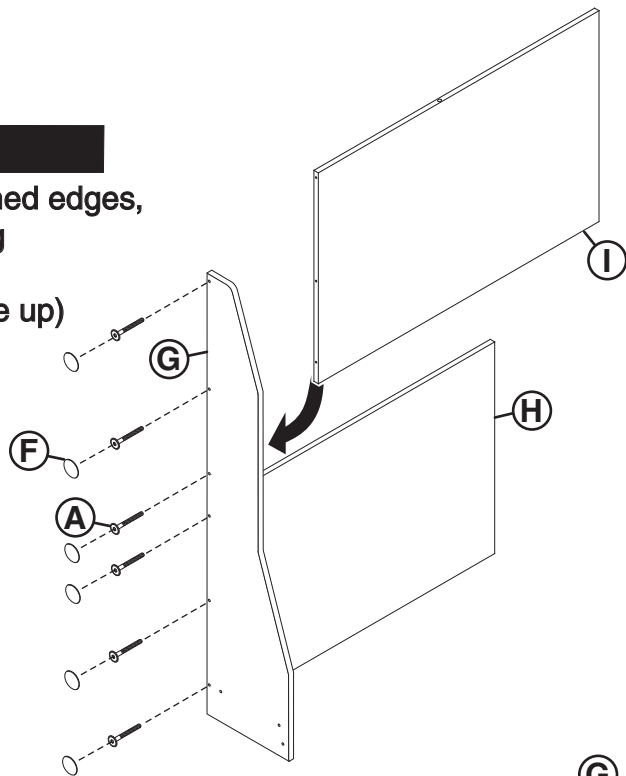

Attach **(1) Kicks (J)** using **(1) Connector Bolt (A)**.

Attach **(1) Bottom Plates (K)** using **(2) Connector Bolts (A)**.

Attach **(3) Connector Bolt Covers (F)**.

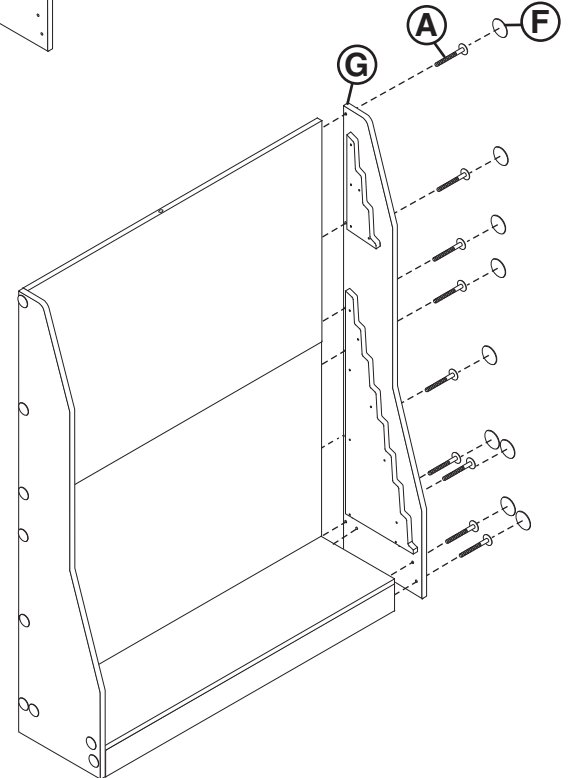

Attach other **Side (G)** using **(9) Connector Bolts (A)**.  
Attach **(9) Connector Bolt Covers (F)**.

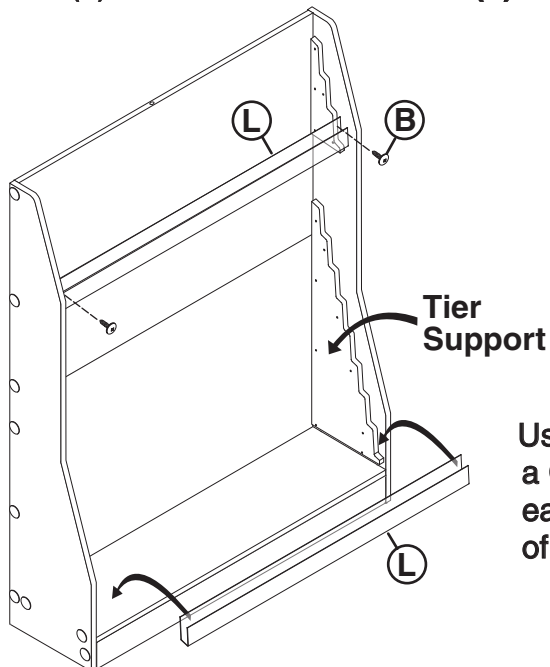

Using **(2 for each) Screws (B)** install a **Clear Rack (L)** at the bottom of each **(2) Tier Support** on inside of **Assembly Side**.

## ASSEMBLY

Starting at bottom of each tier, install a **White Rack (M)** seating the top of the back of the **Clear Rack (L)** in the slot in the lower front of the **White Rack (M)**. Secure the **White Rack (M)** to the Assembly with (2) **Push Pins (C)**. Proceed to install the rest of the **White Racks (M)**, working up and back, securing the back of the rack below in the slot in the rack above, then securing the **White Rack (M)** to the Assembly with (2) **Push Pins (C)**. Insert **Threaded Stud (D)** into **Sign Holder (N)**, then insert Assembly into hole in top of Display.

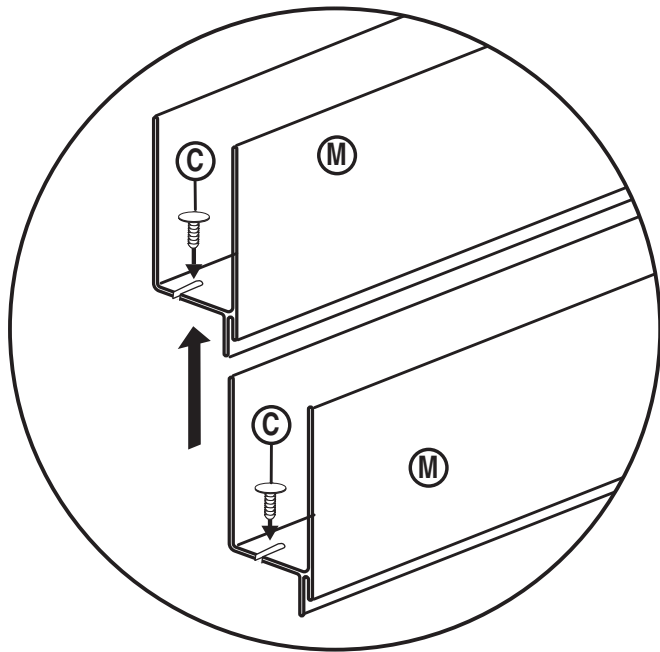

**NOTE:** Make sure back of lower rack is seated completely in slot in bottom of rack above.

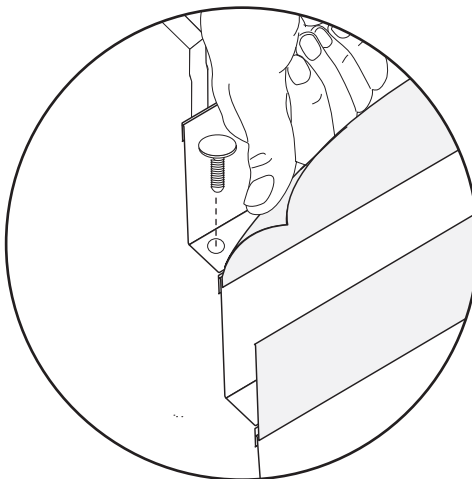
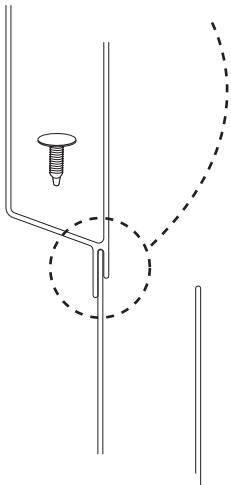

**TIP:** Many installers gently bend the rack open (below) and use the end of a screwdriver handle or hammer handle to press **Push-Pins (C)** firmly into place.

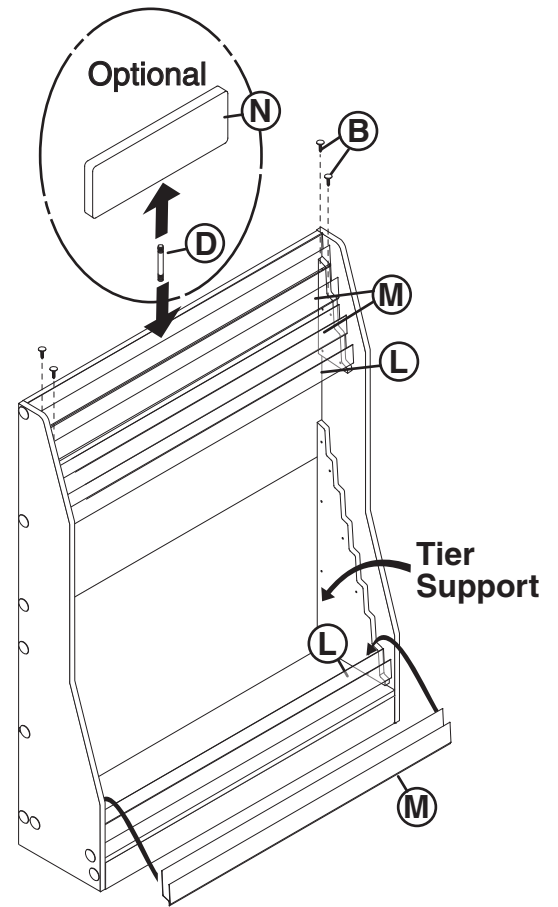

If you have any questions please call:  
UPC Customer Service

1-800-859-7442

Design & Manufacture  
upcdisplays.com

## ASSEMBLY

Insert Card Clips (O).

