

**PARTS BAG** **2876A** **48-Pocket Spinner**

PART	Quantity	Reference
Push Pin	9 (1 extra)	A
Trusshead Screw	4	B
Header Clip	1	C

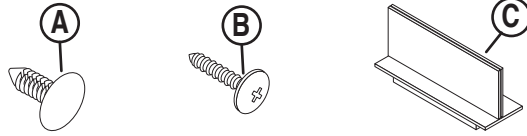

**PARTS LIST**

PART	Quantity	Reference
Tower Panel	2	D
Tower Helper	3	E
Top Cap	1	F
Base	1	G
Racks	48	H

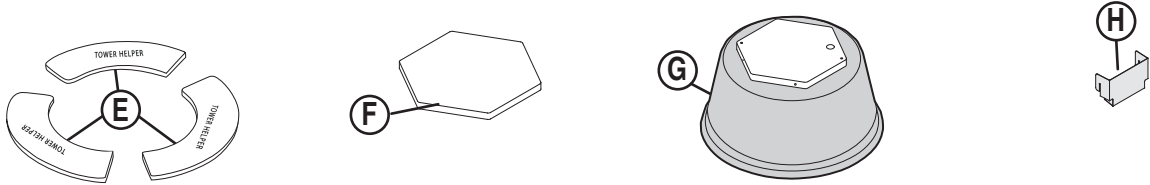
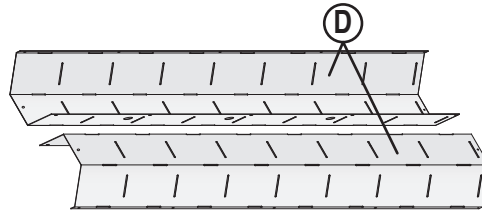

**ASSEMBLY**

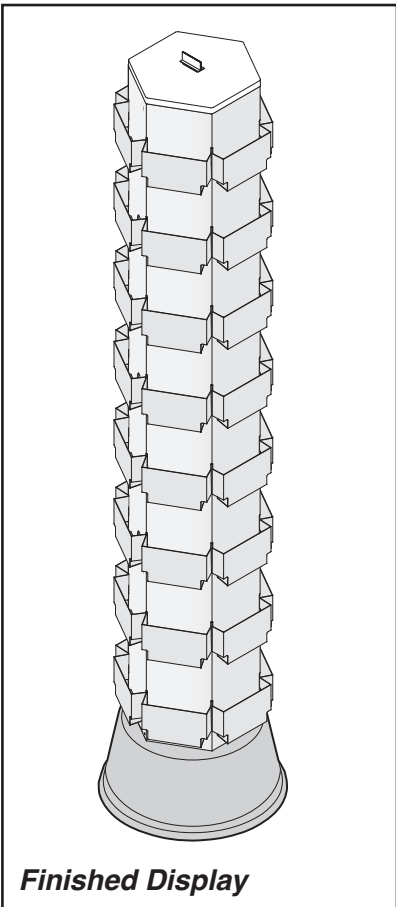

**1** Remove (2) screws from **Base (G)** and discard before beginning assembly.

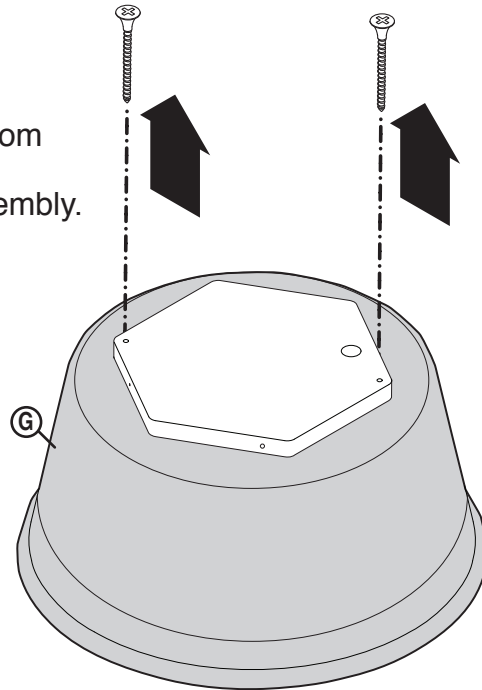

If you have any questions or need replacement parts, please call:  
**UPC Customer Service**  
 1-800-859-7442  
**Design & Manufacture**

# ASSEMBLY

close up view

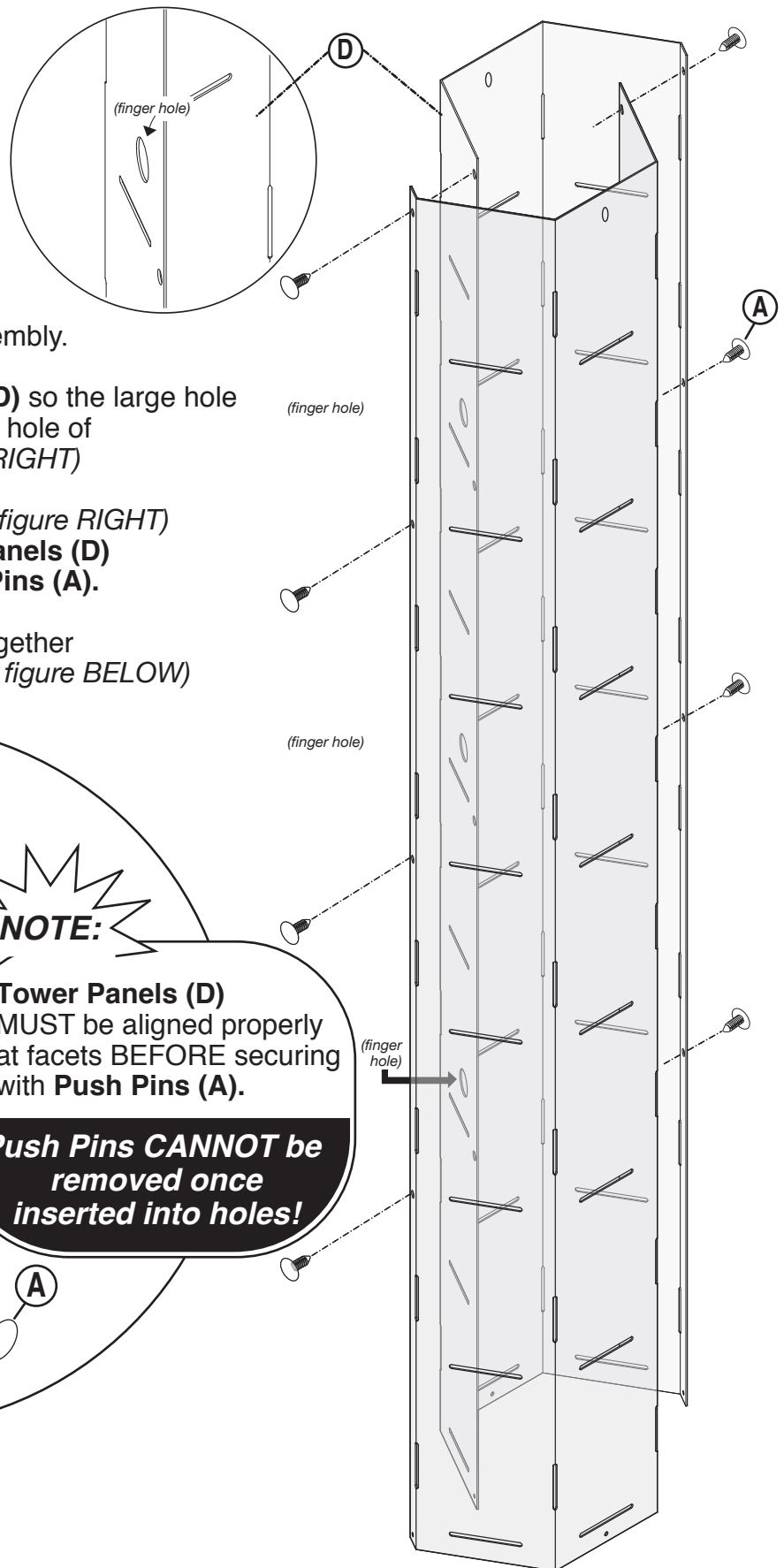

- 2** A. Peel protective masking off **Tower Panels (D)** before assembly.
- B. Overlap each **Tower Panel (D)** so the large hole of facet lies outside the small hole of opposite panel. (see figure RIGHT)
- C. Use Large Finger Holes (see figure RIGHT) to hold together (2) **Tower Panels (D)** tightly while installing **Push Pins (A)**.
- D. Join (2) **Tower Panels (D)** together using (8) **Push Pins (A)**. (see figure BELOW)

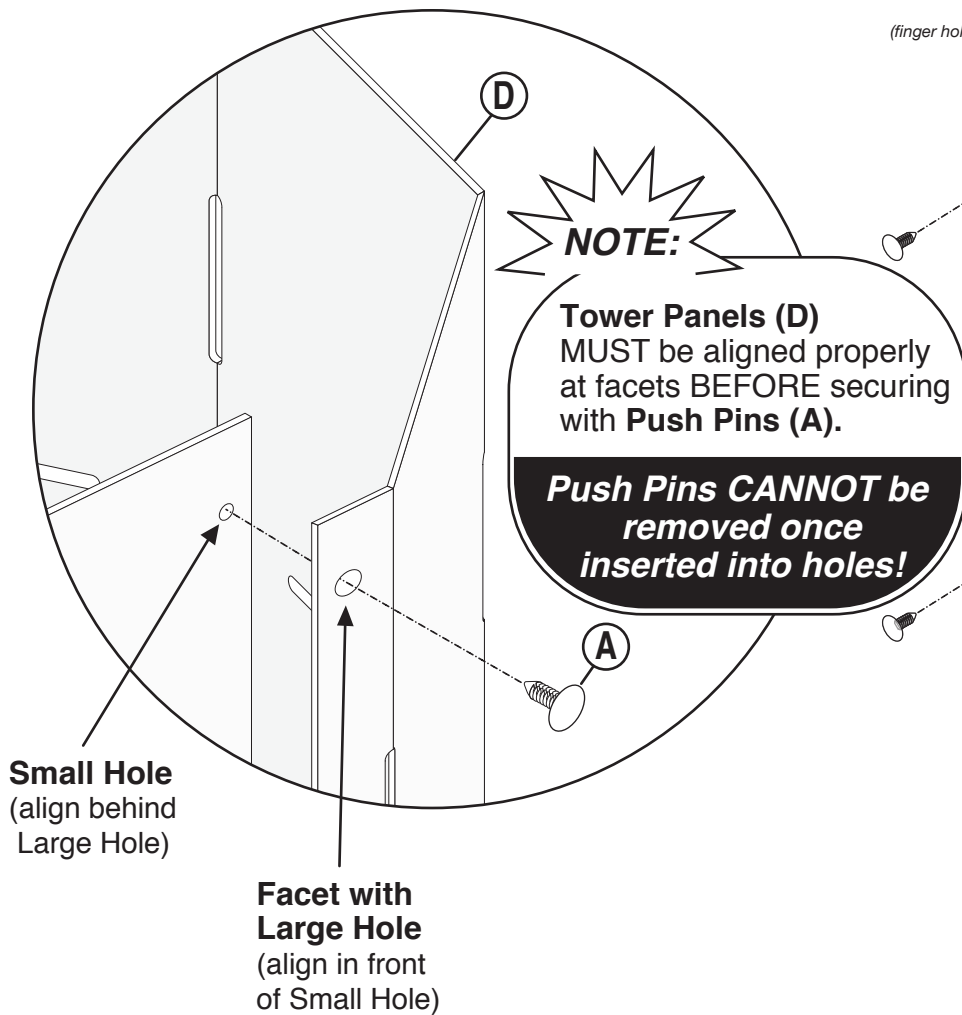

**Small Hole**  
(align behind  
Large Hole)

**Facet with  
Large Hole**  
(align in front  
of Small Hole)

If you have any questions or need replacement parts, please call:

UPC Customer Service  
1-800-859-7442

Design & Manufacture

## ASSEMBLY

- 3** This step will hold **Tower Panel Assemblies (D)** up for installation to **Base (G)**. Insert (3) **Tower Helpers (E)** under spinner plate on Base (*as shown below*).

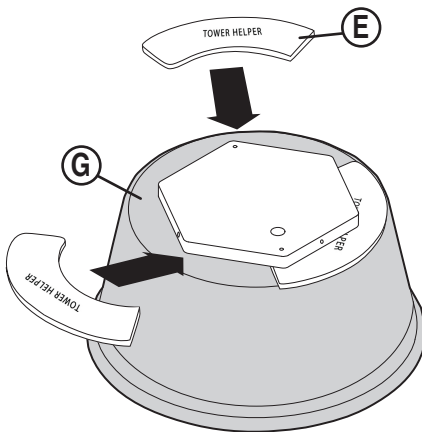

- 4** Align corresponding holes and set the **Tower Panel Assembly (D)** onto the **Base (G)**.

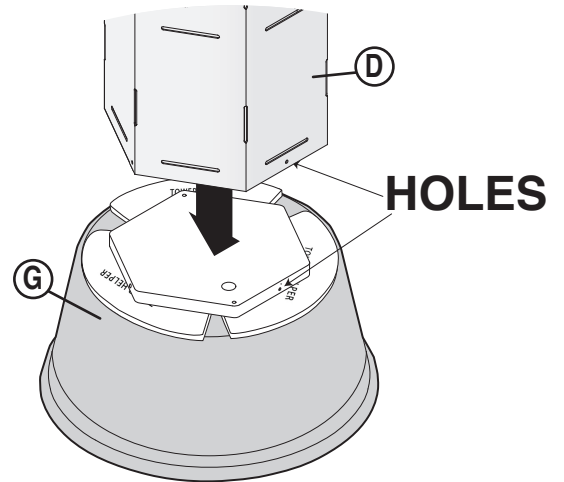

- 5** Secure **Tower Panel Assembly (D)** to **Base (G)** with (4) **Trusshead Screws (B)**.

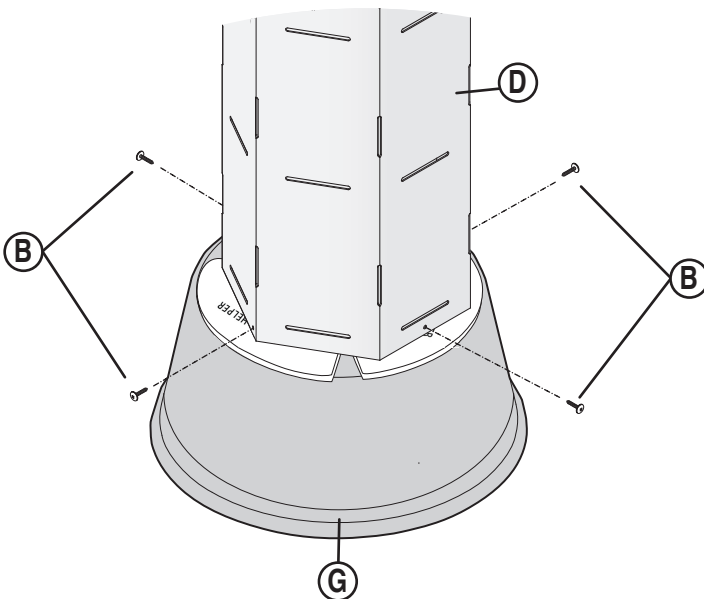

- 6** Remove **Tower Helpers (E)**.

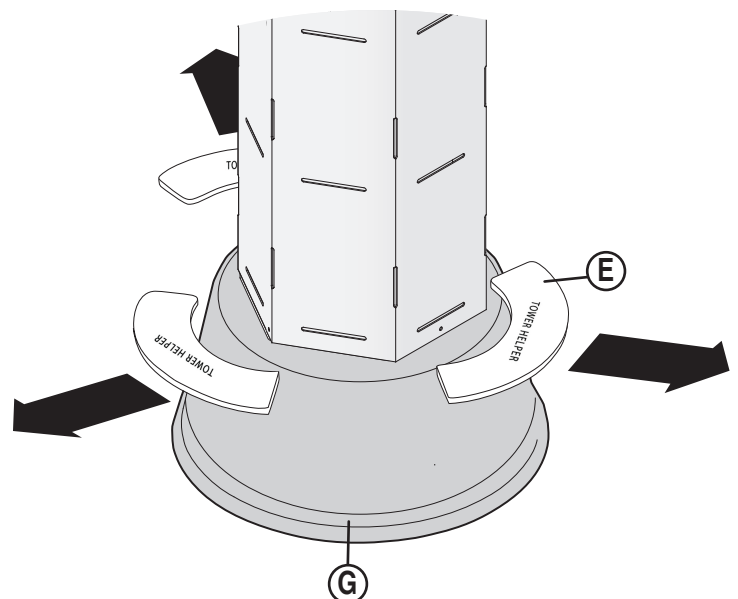

If you have any questions or need replacement parts, please call:

UPC Customer Service  
1-800-859-7442

Design & Manufacture

# ASSEMBLY

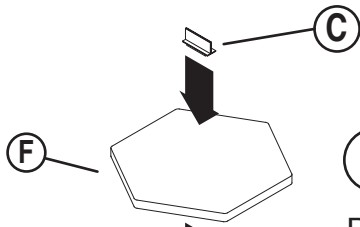

7

Peel masking off of **Header Clip (C)** and secure to the center of the **Top Cap (F)**.

Attach **Top Cap (F)** to the top of the **Tower Panel Assembly (D)**.

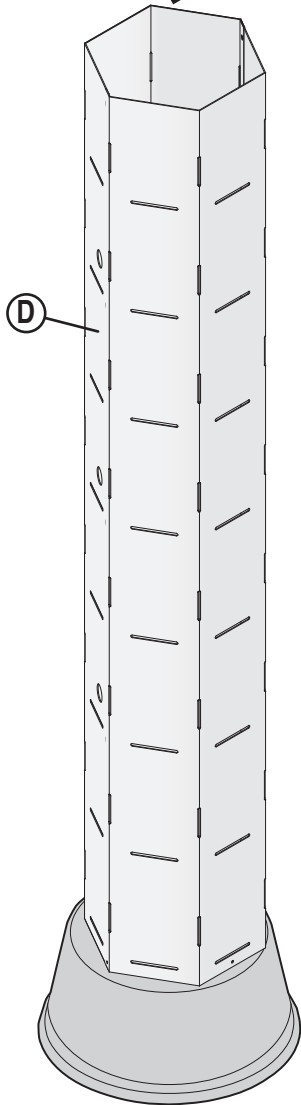

8

Attach **Racks (H)** by hooking the tabs into the vertical slots in the **Tower Panel Assembly (D)**.

Lock bottom tongue of **Racks (H)** into the horizontal slots on the **Tower Panel Assembly (D)**.

Each vertical slot holds two **Racks (H)** side by side.

