

**PARTS LIST**      **UPC#2568/#2567**      **Slotted Upright Installation**

PART	Quantity	Reference
Slotted Uprights	2	A
Slotted Upright Keys	2	B

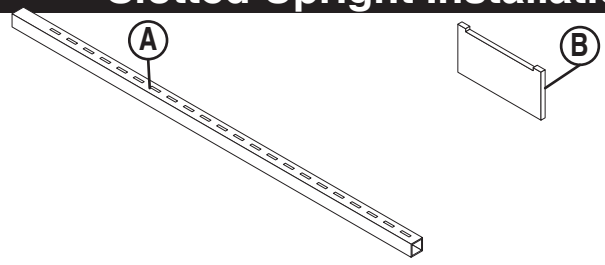

**ASSEMBLY**

**1** Place the **Slotted Upright Keys (B)** into the desired slots making sure the notches face up.

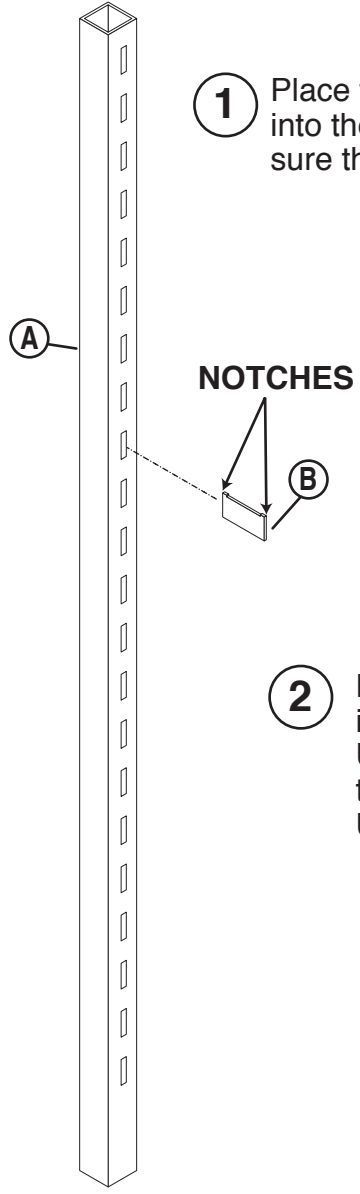

**2** Hold the **Slotted Upright Keys (B)** in place and slide the **Slotted Uprights (A)** into the fixture until they rest on the **Slotted Upright Keys (B)**.

