

PARTS BAG

UPC 2392

Casters for 48" Island Display

PART	Quantity	Reference
Screws	4	A
Locking Casters	4	B

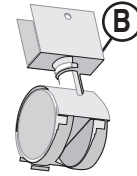
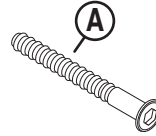

TOOLS REQUIRED: #2 Phillips Screwdriver

If Panels are Pre-Drilled for Casters...

Attach (2) **Locking Casters (B)** to each **Side Panel** with **Phillips Screws (A)**.

Note: Casters have one *Smaller Threaded Hole* and one *Larger Un-Threaded Hole*. Insert Screw through *Larger-Un-Threaded Hole FIRST*, then through Panel, Then Screw into *Threaded Side*.

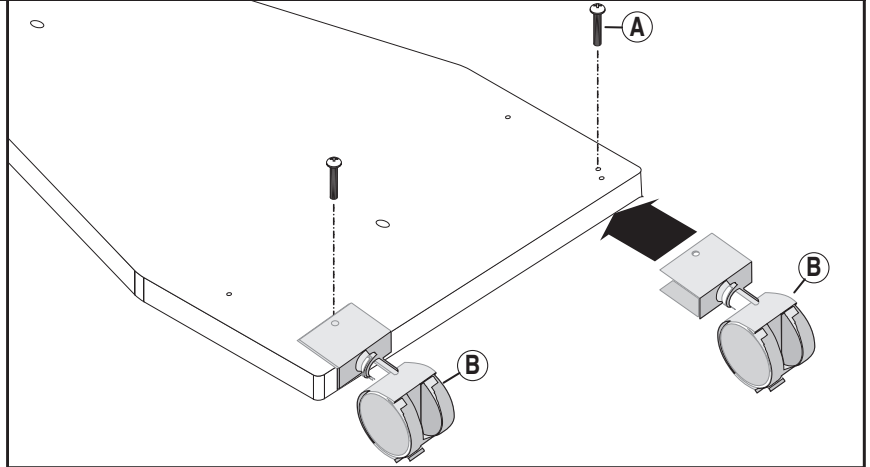

If Panels are NOT Pre-Drilled for Casters...

Position **Locking Caster (B)** over bottom edge of a **Side Panel** – *with large hole up*, about 1/2" from front or back edge, and mark position of hole with pencil or drill. Mark holes for 3 more **Locking Casters (B)** the same way.

Remove Locking Caster (B).

Drill (4) holes through **Side Panels** where marked.

Attach (2) **Locking Casters (B)** to each **Side Panel** with **Phillips Screws (A)**.

OTHER TOOLS REQUIRED: Drill & 3/16" Bit

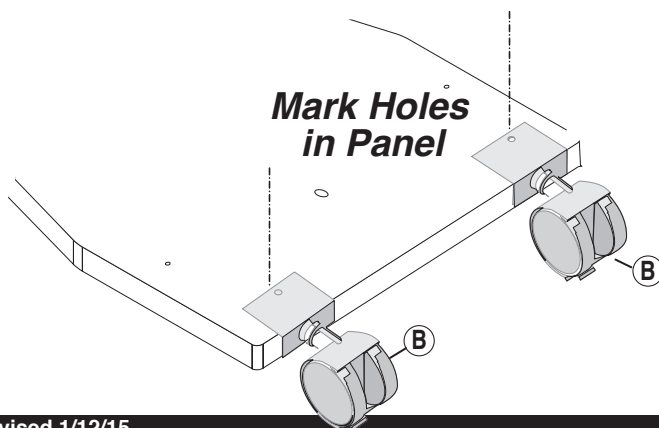
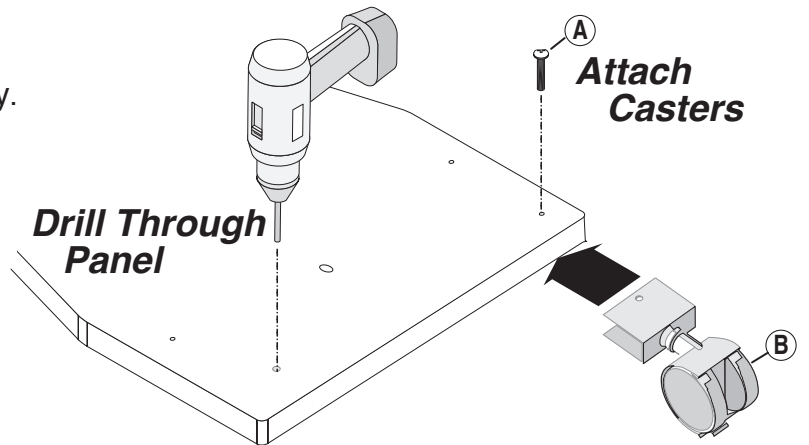

Do NOT drill through Small Threaded Hole In Casters!

If you have any questions or need replacement parts, please call:
UPC Customer Service
1-800-859-7442
Design & Manufacture