

PARTS BAG UPC#2014B 4-Per 5" Kickout for Tiered Fixtures

| PART | Quantity | Reference |
|-------------------------|----------|-----------|
| Screw Post Sets | 16 | A |
| Slatwall Adapters | 8 | B |
| Phillips Panhead Screws | 8 | C |
| Wall Togglers | 8 | D |

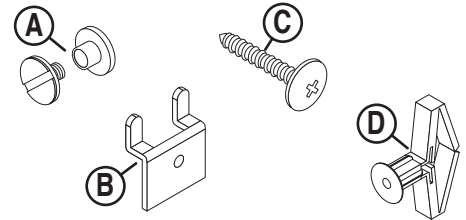

**TOOLS REQUIRED: Flathead Screwdriver (Slatwall/Drywall)
Drill with 3/8" Drywall Bit & Phillips Screwdriver (Drywall)**

PARTS LIST

| PART | Quantity | Reference |
|---------------|----------|-----------|
| Left Kickout | 4 | E |
| Right Kickout | 4 | F |

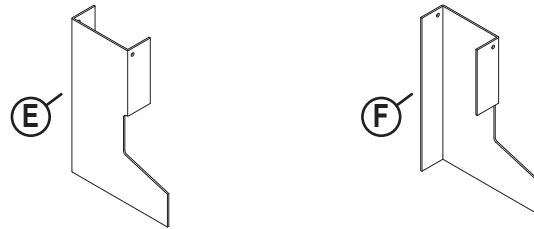

SLATWALL ASSEMBLY

NOTE: Assemble for EITHER Slatwall or Drywall, not both.

- 1 Attach **Left Kickout (E)** and **Right Kickout (F)** to **Existing or New Rack** using (2) **Screw Post Sets (A)**.

- 2 Attach the **Slatwall Adapters (B)** to **Left and Right Kickouts (E&F)** using (2) **Screw Post Sets (A)**.
Insert the entire **Rack** into the slatwall.

Repeat Steps 1-2 for remaining Racks.

Note:

If you have hardware on your existing rack remove hardware before attaching kickouts and slatwall adapters.

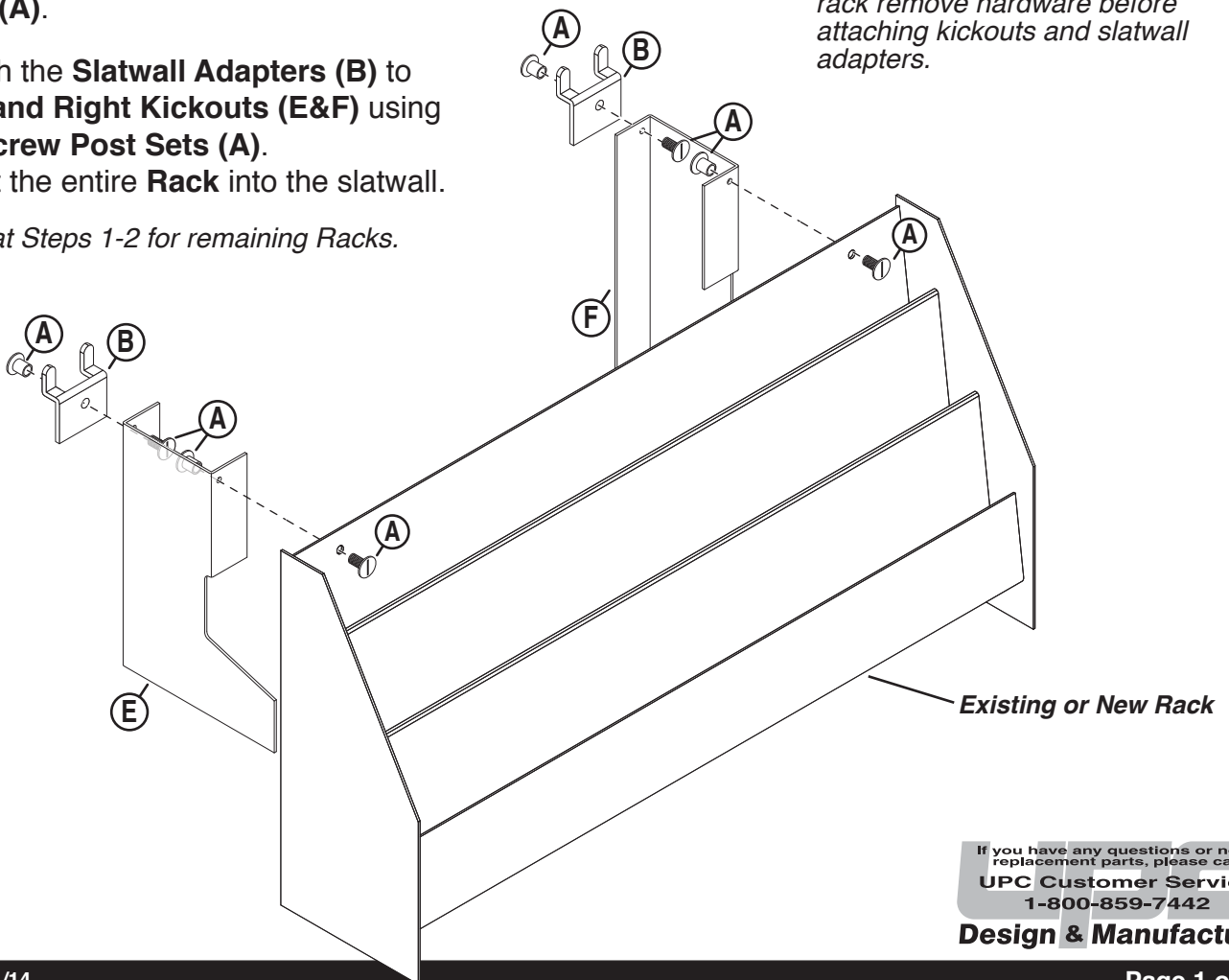

If you have any questions or need replacement parts, please call:
UPC Customer Service
1-800-859-7442

Design & Manufacture

DRYWALL ASSEMBLY

NOTE: Assemble for EITHER Slatwall or Drywall, not both.

- 1 Attach **Left Kickout (E)** and **Right Kickout (F)** to **Existing or New Rack** using (2) **Screw Post Sets (A)**.

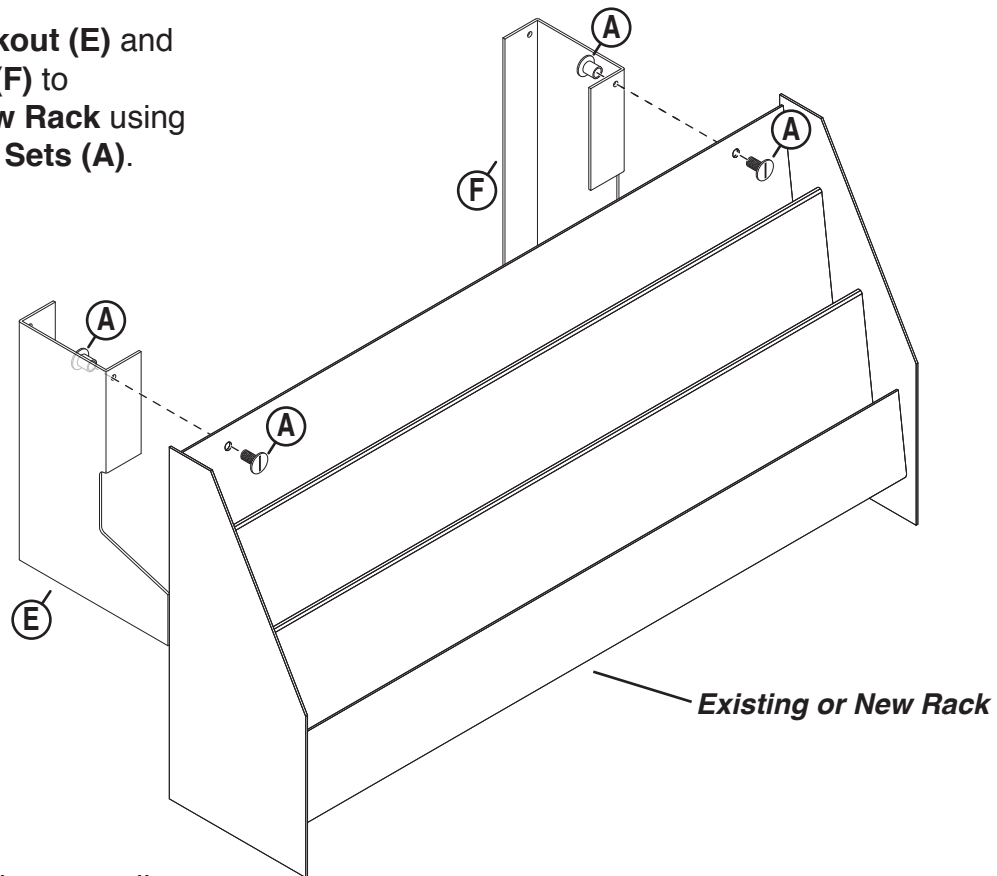

- 2 Determine position on wall and drill 3/8" holes. Squeeze **Wall Toggles (D)** flat and insert into hole. Tap flange flush with wall.

- 3 Place **Rack with Kickouts (E&F)** against **Wall Toggles (D)** and insert **Screw (C)**, tightening until secure.

Repeat Steps 1-3 for remaining Racks.

