

PARTS BAG

UPC 1465

96 Pocket Legacy Spinner

PART	Quantity	Reference
Small Head Connector Bolt	8	A
Large Head Connector Bolt	4	B
Push Pin	68 (4 extra)	C
Short Trusshead Screw	4	D
Hex Wrench (3mm)	1	E
Hex Wrench (4mm)	1	F
Header Clip	1	G
Card Clip	84 (20 extra)	H

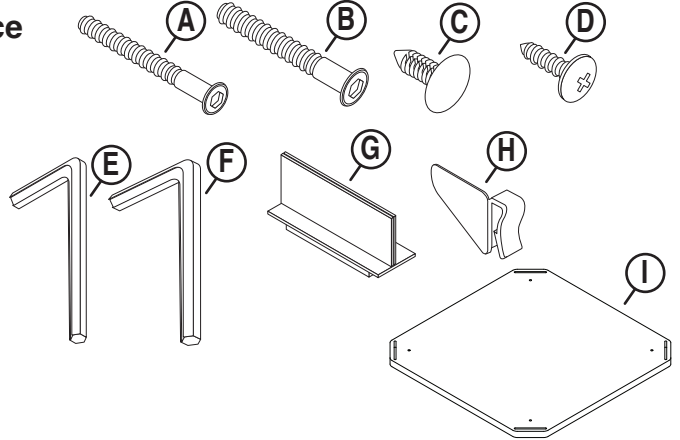

TOOLS REQUIRED: #2 Phillips Screwdriver

PARTS LIST

PART	Quantity	Reference
Top Cap	1	I
Corner Post	4	J
Spinner Plate Assembly	1	K
Base	1	L
X-Base Upper	1	M
X-Base Lower	1	N
Pocket	32	O

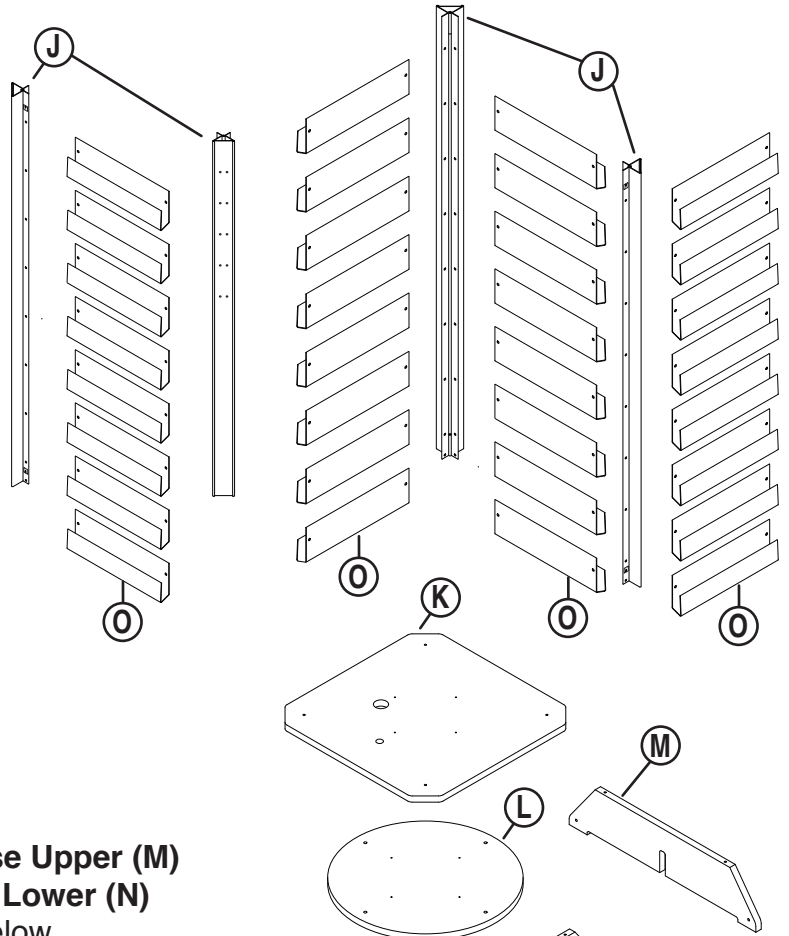

1 Insert X-Base Upper (M) into X-Base Lower (N) as shown below.

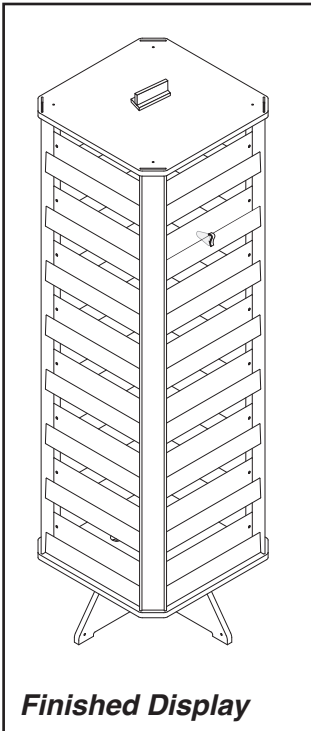
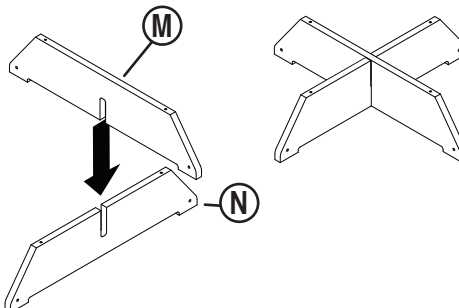

If you have any questions or need replacement parts, please call:
UPC Customer Service
 1-800-859-7442
Design & Manufacture

If you have any questions or need replacement parts, please call:
UPC Customer Service
1-800-859-7442

Design & Manufacture

ASSEMBLY

- 2** Attach **Base (L)** to **X-Base Assembly (M/N)** using **(4) Large Head Connector Bolts (B)**.

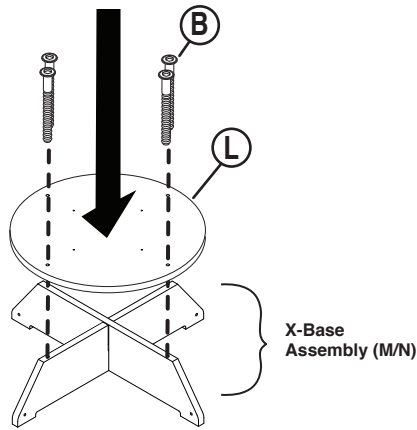

- 3** Spin and align the large holes in **Spinner Plate** with **Spinner**.

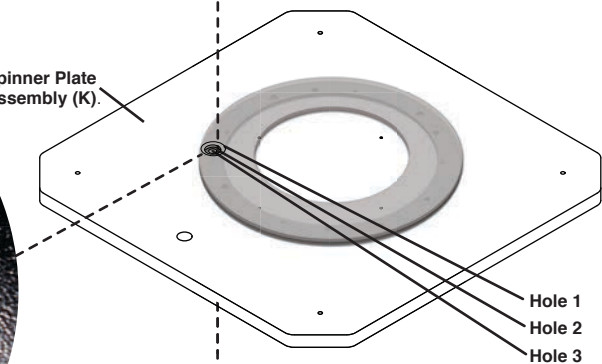
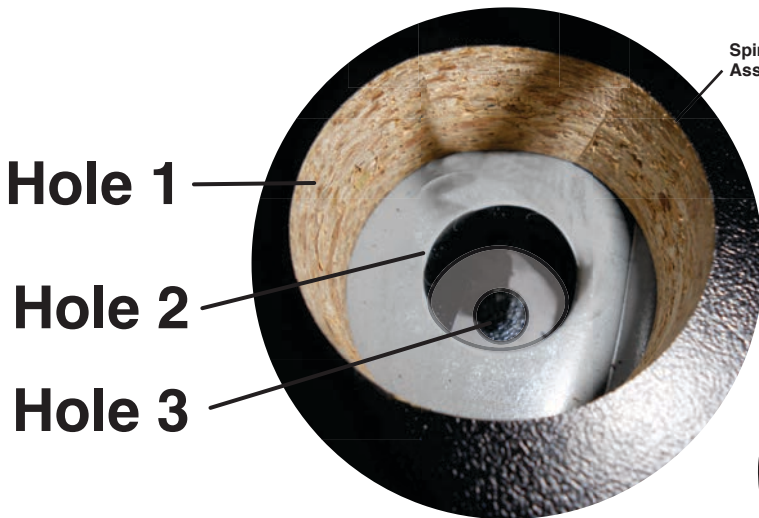
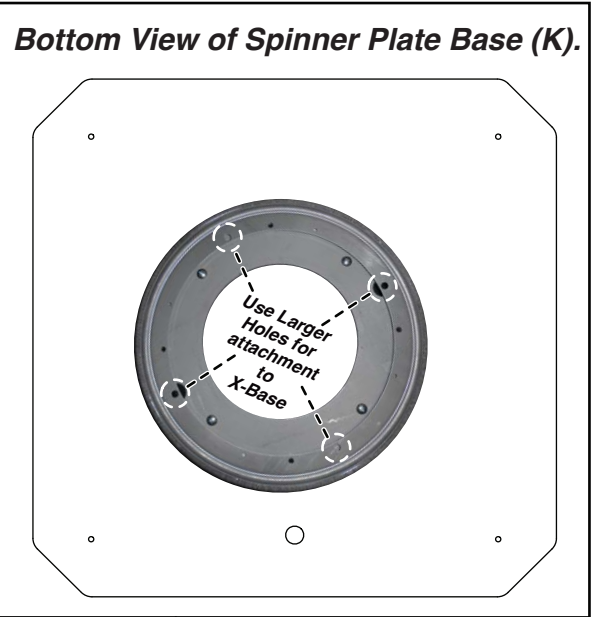
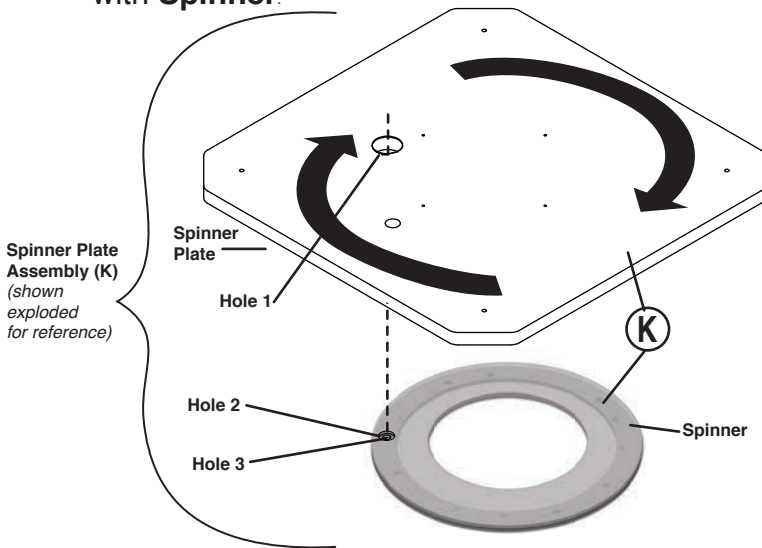

- 4** Align large screw holes on **Spinner Plate Assembly (K)** with one of the four corresponding holes on the **X-Base Assembly**.

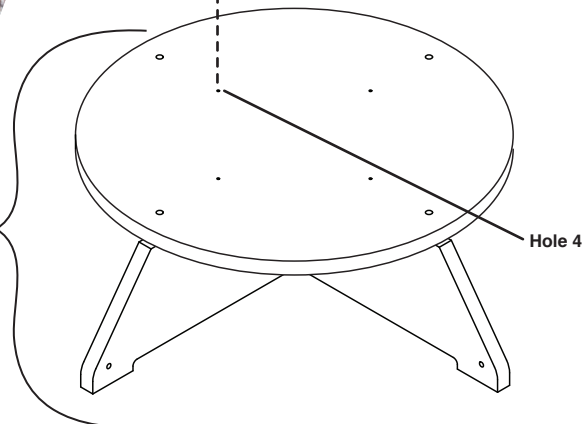

If you have any questions or need replacement parts, please call:
UPC Customer Service
1-800-859-7442

Design & Manufacture ASSEMBLY

- 5** Attach **Spinner Plate Assembly (K)** to **X-Base Assembly** by using (1) **Short Trusshead Screw (D)** through large screw hole in **Spinner Plate (K)** to hole in **X-Base Assembly**. **DO NOT** tighten completely!

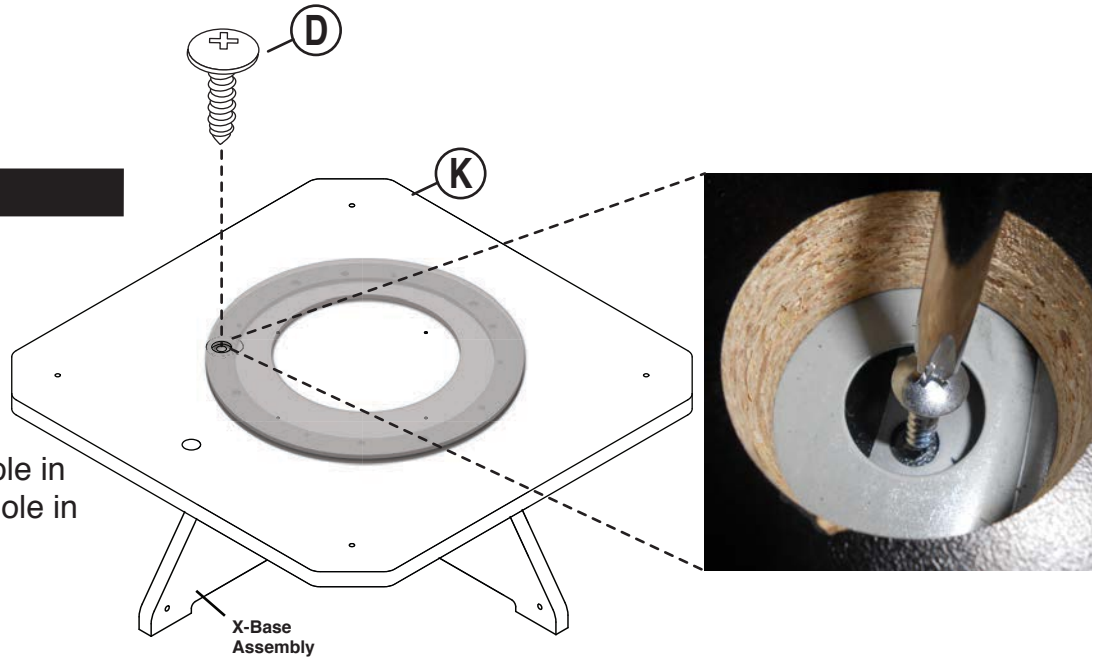

- 6** Turn **Spinner Plate Assembly (K)** 90° to continue attachment to **X-Base Assembly**, slight positioning adjustment may be necessary to find hole. To attach **Spinner Plate (K)**, use 2nd **Short Trusshead Screw (D)** through large hole to corresponding hole of **X-Base Assembly**.

- 7** Repeat Step 6 for attaching **Spinner Plate Assembly (K)** to **X-Base Assembly** using 3rd & 4th **Short Trusshead Screws (D)**. Tighten all screws.

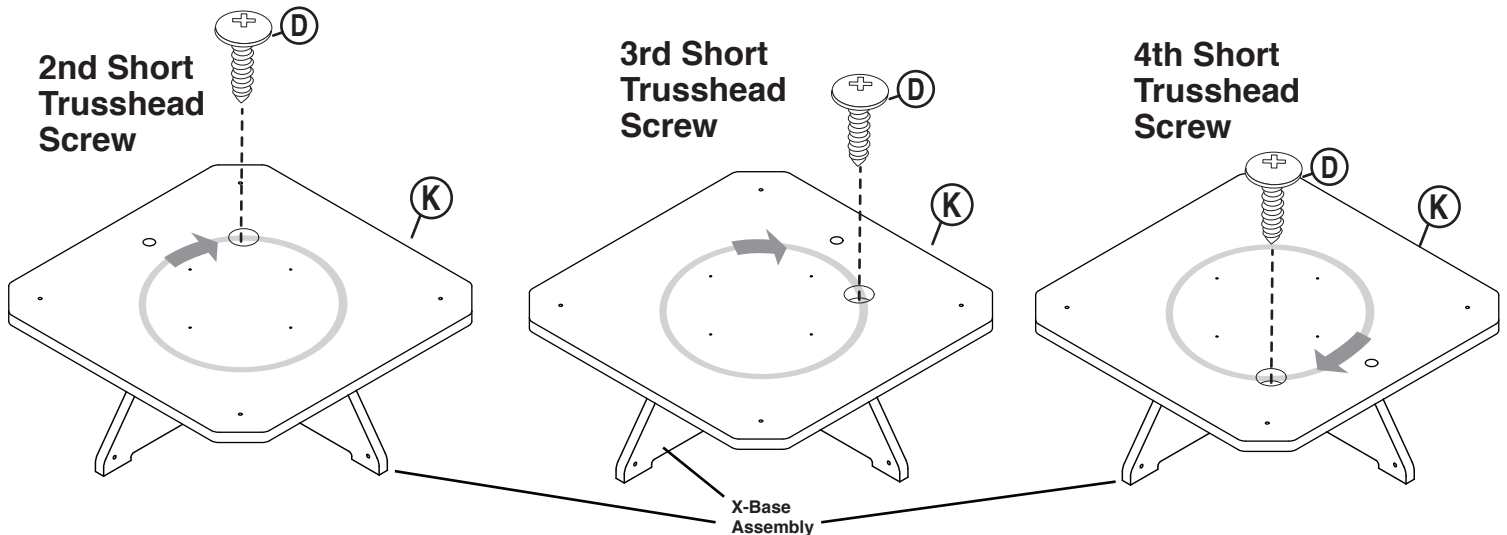

8

STOP!

STOP! If you are installing casters, please refer to instruction sheet #14532 enclosed in your caster kit.

ASSEMBLY

- 8** Identify Top and Bottom of (4) **Corner Posts (J)**.
NOTE: Holes are further from the top than the bottom.

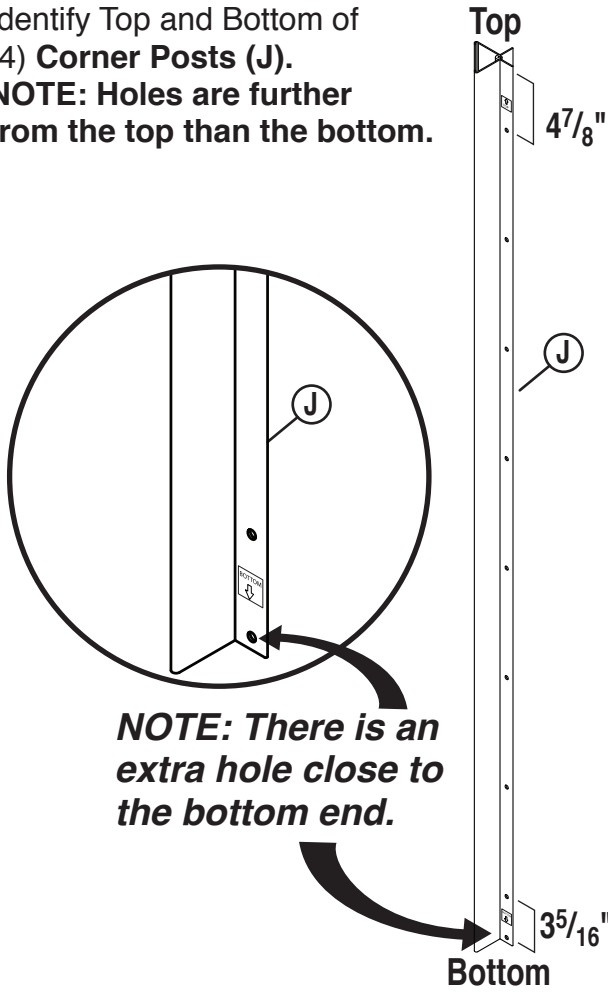

NOTE: There is an extra hole close to the bottom end.

- 9** Attach (4) **Corner Posts (J)** to the **Spinner Plate Assembly (K)** using (4) **Small Head Connector Bolt (A)**, as shown.
Top must be up, bottom down.

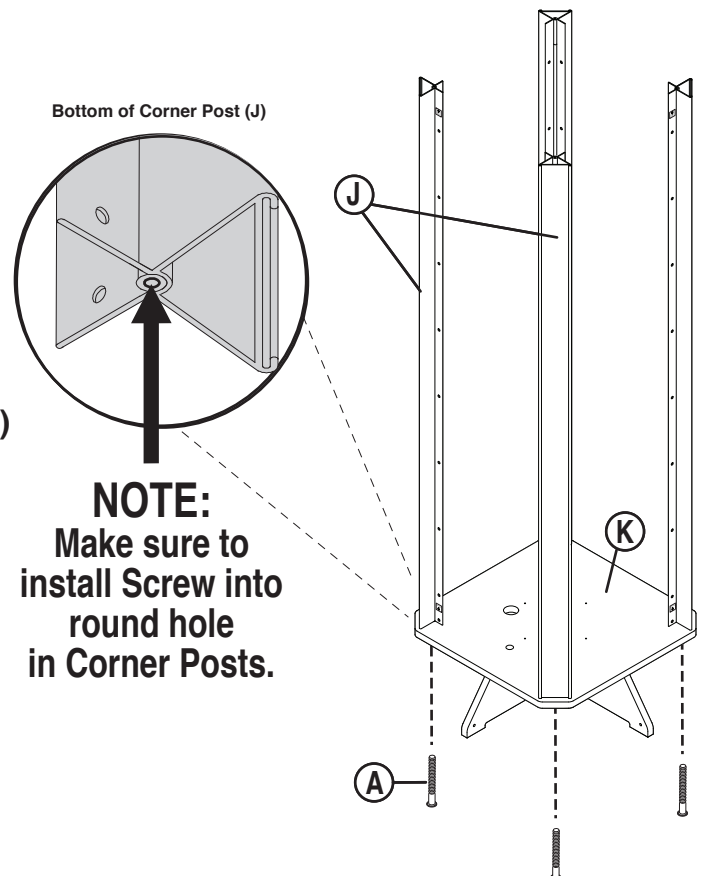

If you have any questions or need replacement parts, please call:

UPC Customer Service
1-800-859-7442

Design & Manufacture

ASSEMBLY

- 10** Push (2) **Push Pins (C)** into each **Pocket (O)** then attach to **Corner Posts (J)**.

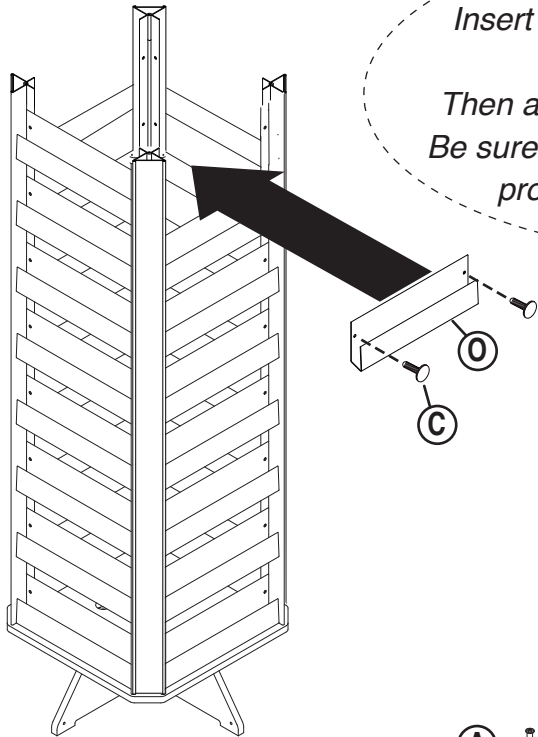

Important Note:

Insert **Push Pins (C)** through holes in **Pockets (O)** **FIRST**
Then attach **Pocket Assembly** to **Tower**.
Be sure **Push Pins** are tight - the **Pockets** provide the rigidity of the tower.

- 11** Attach **Top Cap (I)** onto **Corner Posts (J)** with (4) **Small Head Connector Bolts (A)**. Insert **Card Clips (H)** where needed. Attach **Header Clip (G)** in center of **Top Cap (I)**.

