

ASSEMBLY INSTRUCTIONS

Thank you for your purchase of one of many fine products designed & manufactured by UPC. We have made every effort to make your assembly easy, clear & hassle free. For more information or if you have any questions contact customer service at 1-800-859-7442.

PARTS BAG

UPC #1461

UPC - Slotwall Pinwheel Spinner

PART	Quantity	Reference
Header Clip	1	A
Hex Wrench	1	B
Connector Bolt	24 (1 Extra)	C

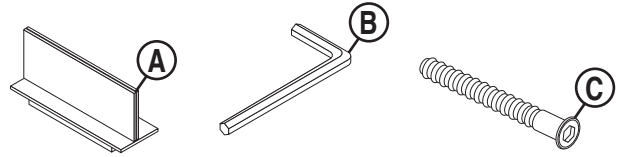

PARTS LIST

PART	Quantity	Reference
Top Cap	1	D
Slotwall Panel	4	E
Base	1	F

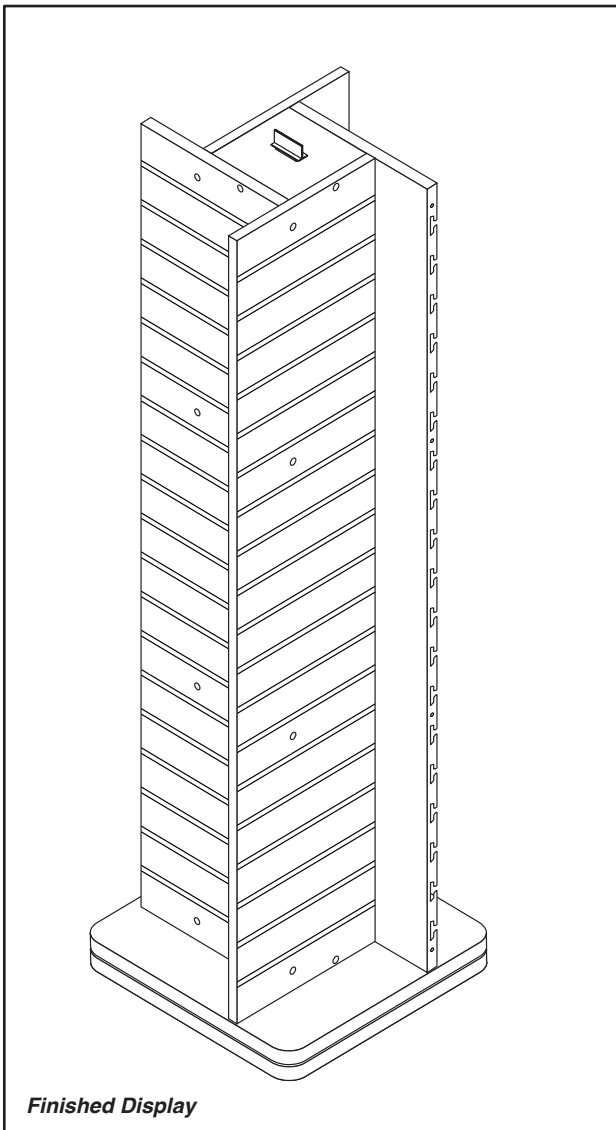
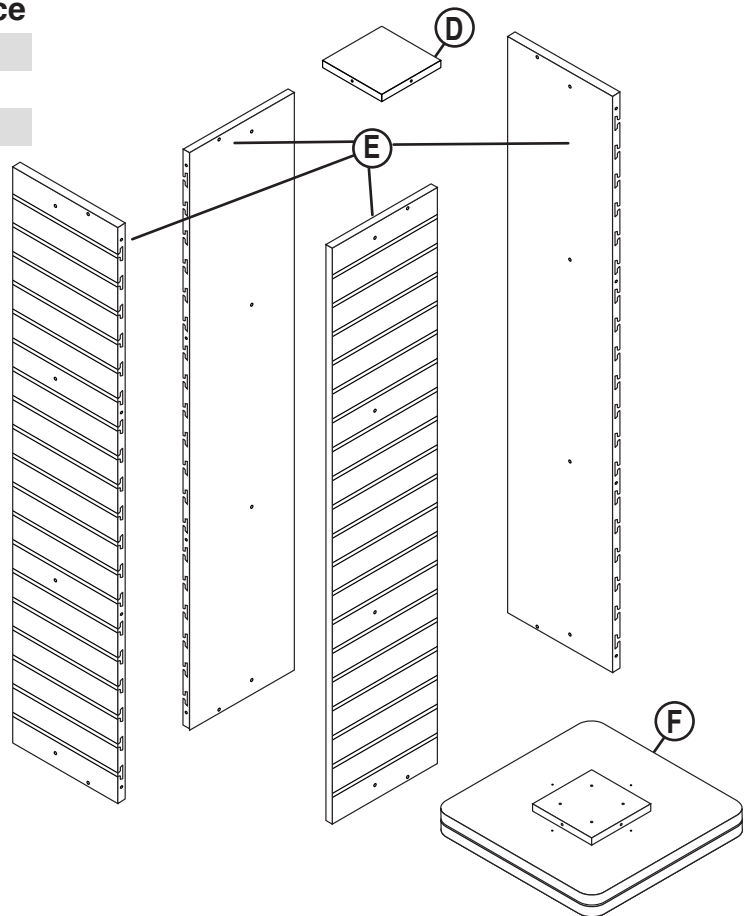

Finished Display

If you have any questions please call:
UPC Customer Service

1-800-859-7442
Design & Manufacture
upcdisplays.com

ASSEMBLY

- 1 Stand up (1) **Slotwall Panel (E)** with the finished edge up and the slots facing toward you. Line up 2nd **Slotwall Panel (E)** to form a "T" with the first as shown. Align and Attach the two panels as shown below using (4) **Connector Bolts (C)** in the pre-drilled holes using **Hex Wrench (B)**.

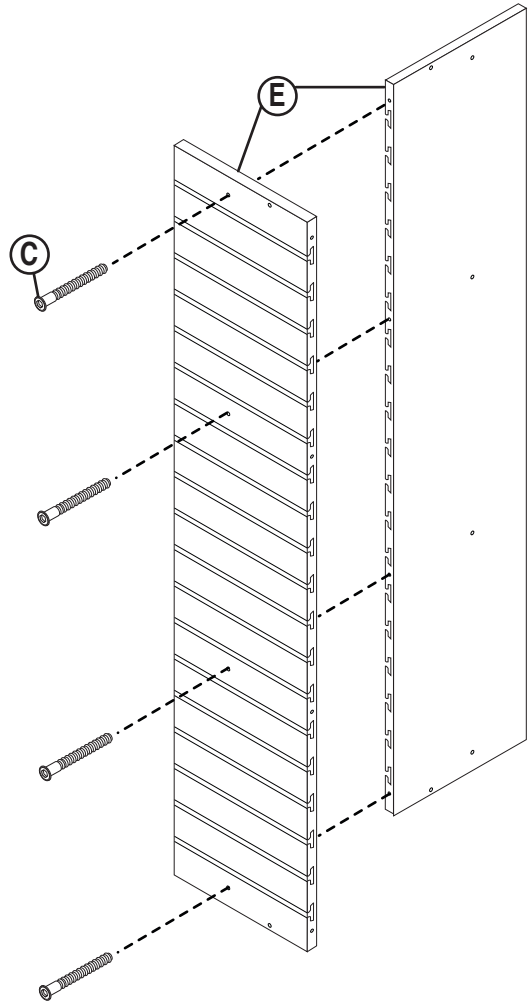

- 2 Hold **Top Cap (D)** into place, align and attach to (2) **Slotwall Panels (E)** using (2) **Connector Bolts (C)** and **Hex Wrench (B)**.

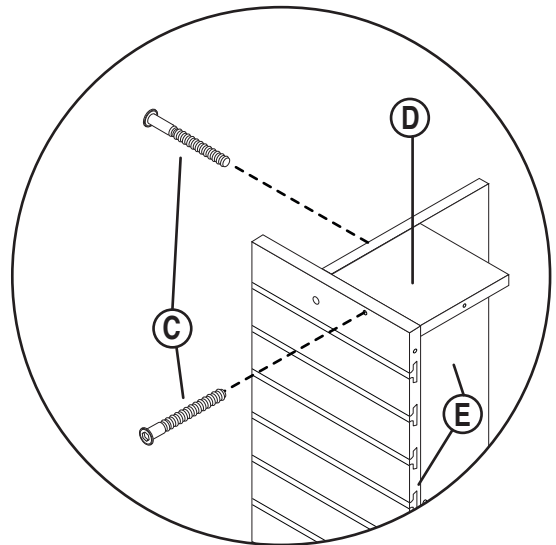

If you have any questions please call:

UPC Customer Service

1-800-859-7442

Design & Manufacture
upcdisplays.com

ASSEMBLY

- 3** Align and Attach 3rd Slotwall Panel (E) to assembly as shown on right using (4) Connector Bolts (C) and Hex Wrench (B).
Align & Attach 3rd Slotwall Panel (E) to Top Cap (D) using (1) Connector Bolts (C) using Hex Wrench (B).

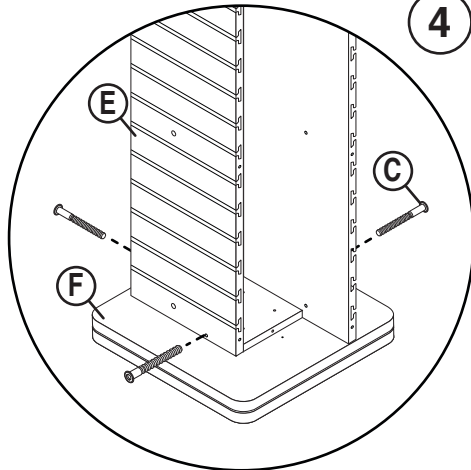
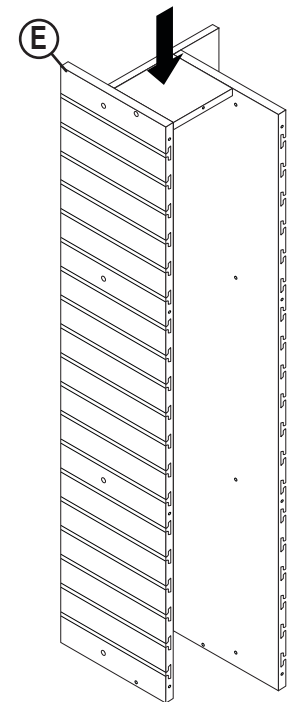
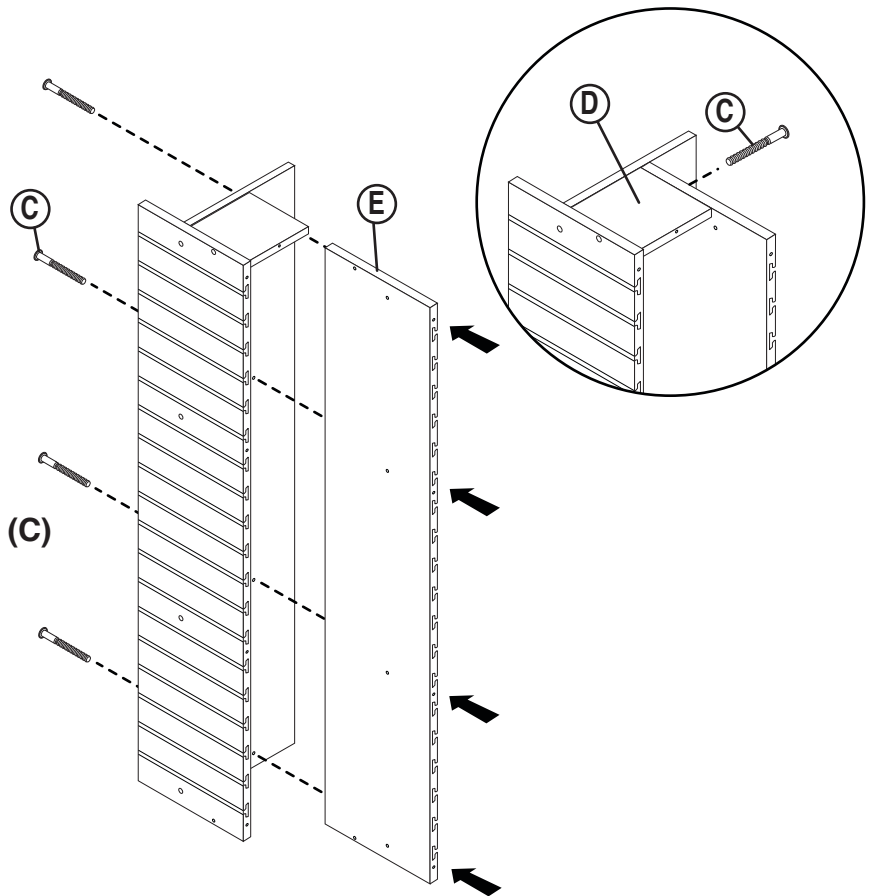

- 4** Place the Slotwall Panel Assembly (E) onto Base (F) and line up pre-drilled holes at the bottom of Slotwall Panel Assembly (E) with holes in base using (3) Connector Bolts (C) using Hex Wrench (B).

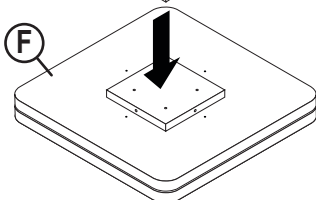

ASSEMBLY

- 5 Align and attach the 4th **Slotwall Panel (E)** to **Assembly (D, E, F)** by using **(8) Connector Bolts (C)** using **Hex Wrench (B)**.

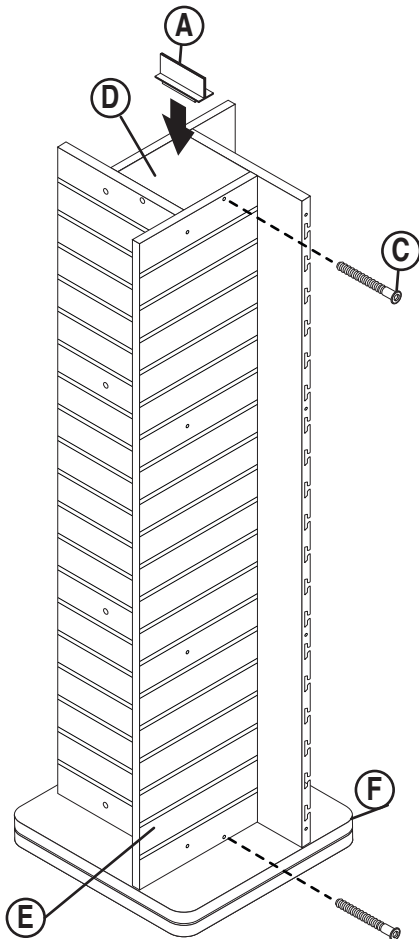
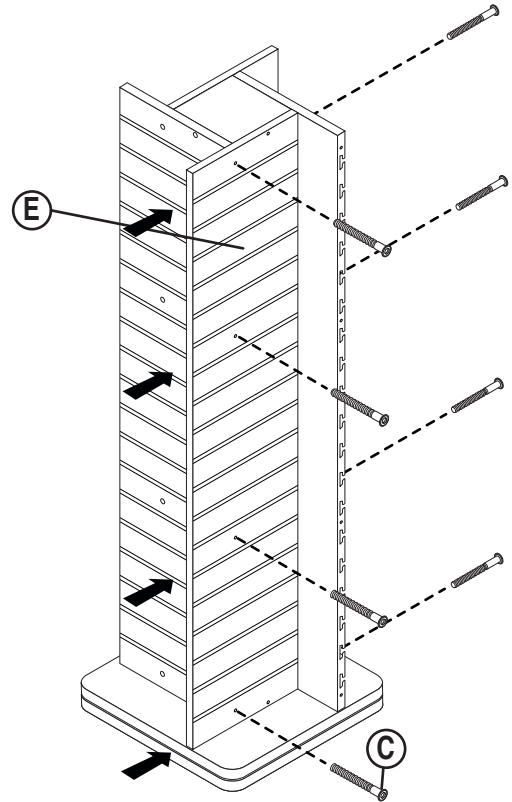

- 6 Complete assembly by aligning and attaching the 4th **Slotwall Panel (E)** to the top and bottom of the **Assembly (D, E, F)** by using **(2) Connector Bolts (C)** using **Hex Wrench (B)**.

Peel protective layer from **Header Clip (A)** and attach to **Top Cap (D)**.