

PARTS BAG UPC 1455A 14552 Icon 56 Pocket Spinner

PART	Quantity	Reference
Push Pin	9 (1 extra)	A
Long Trusshead Screw	4	B
Connector Bolt	4	C
Short Trusshead Screw	4	D
Hex Wrench	1	E
Header Clip	1	F

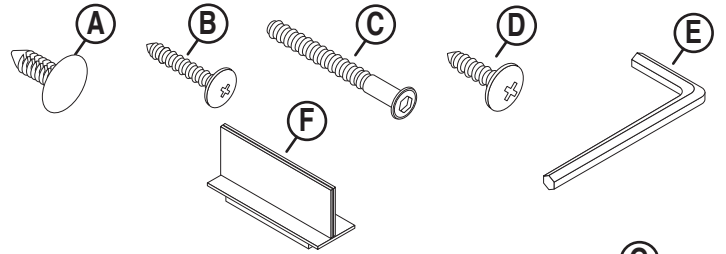

TOOLS REQUIRED: #2 Phillips Screwdriver

PARTS LIST

PART	Quantity	Reference
Top Cap	1	G
Tower Panel	2	H
Spinner Plate Assembly	1	I
Base	1	J
X-Base Lower	1	K
X-Base Upper	1	L
Racks	56	M
Tower Helper	2	N

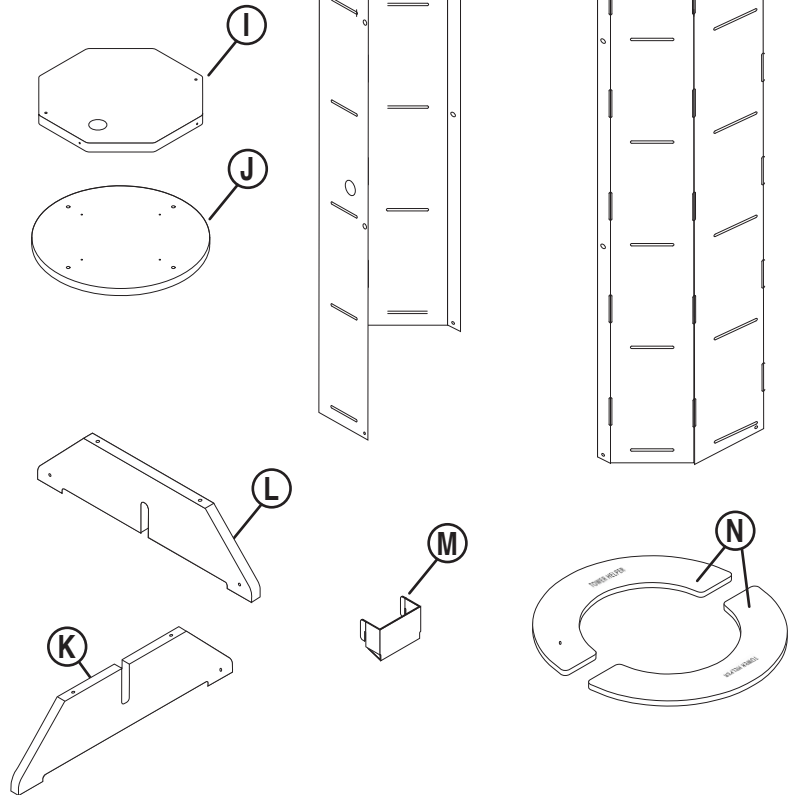
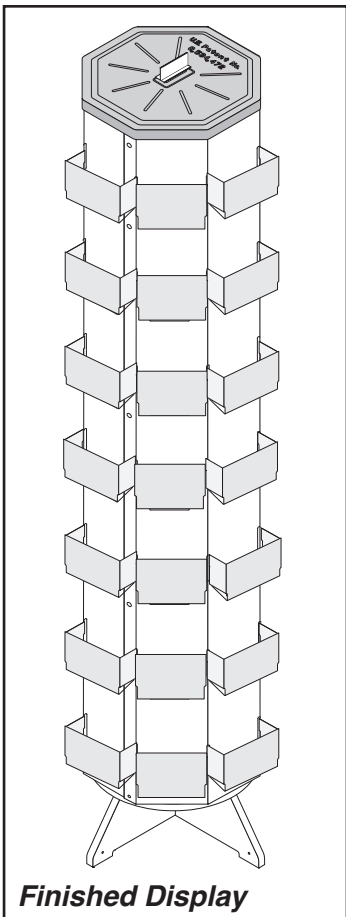
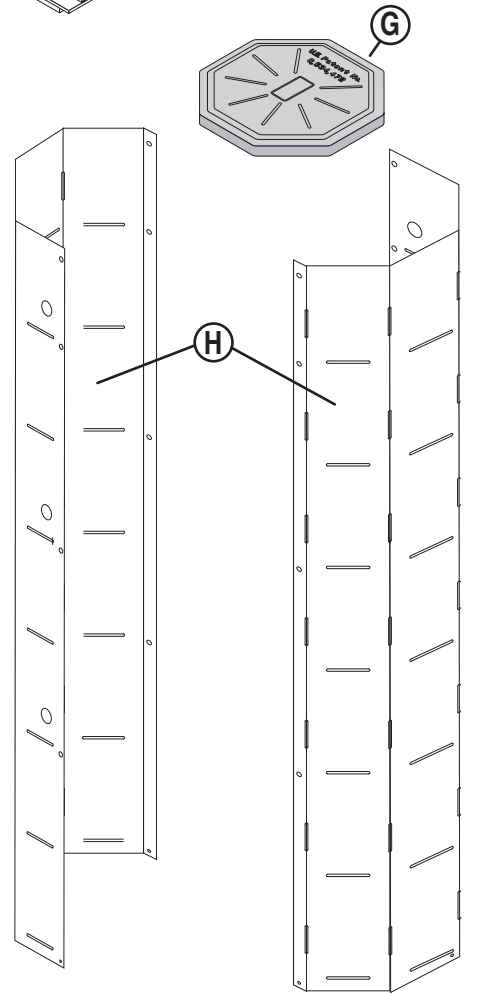

If you have any questions or need replacement parts, please call:
UPC Customer Service
 1-800-859-7442
Design & Manufacture

If you have any questions or need replacement parts, please call:

UPC Customer Service
1-800-859-7442

Design & Manufacture

ASSEMBLY

- 1 Insert **X-Base Upper (L)** into **X-Base Lower (K)** as shown below.

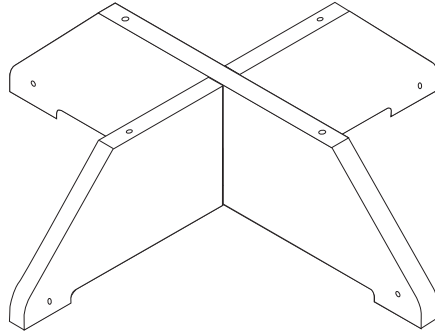
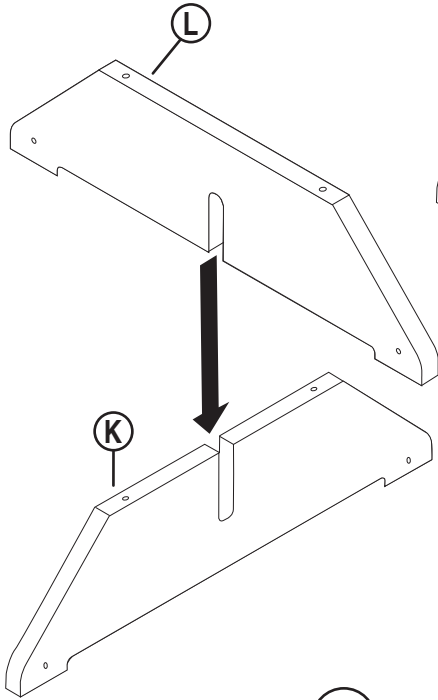

- 2 Attach **Base (J)** to **X-Base Assembly (K/L)** using (4) **Connector Bolts (C)**.

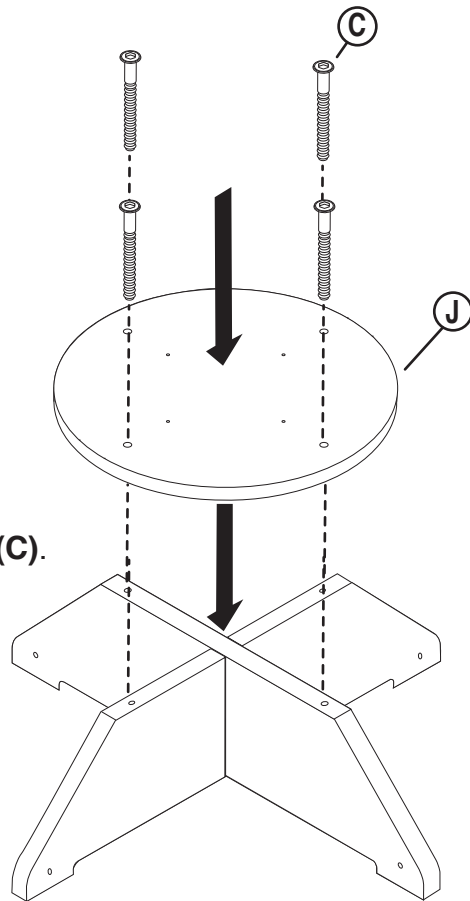

ASSEMBLY

3 Spin and align the large holes in **Spinner Plate** with **Spinner**.

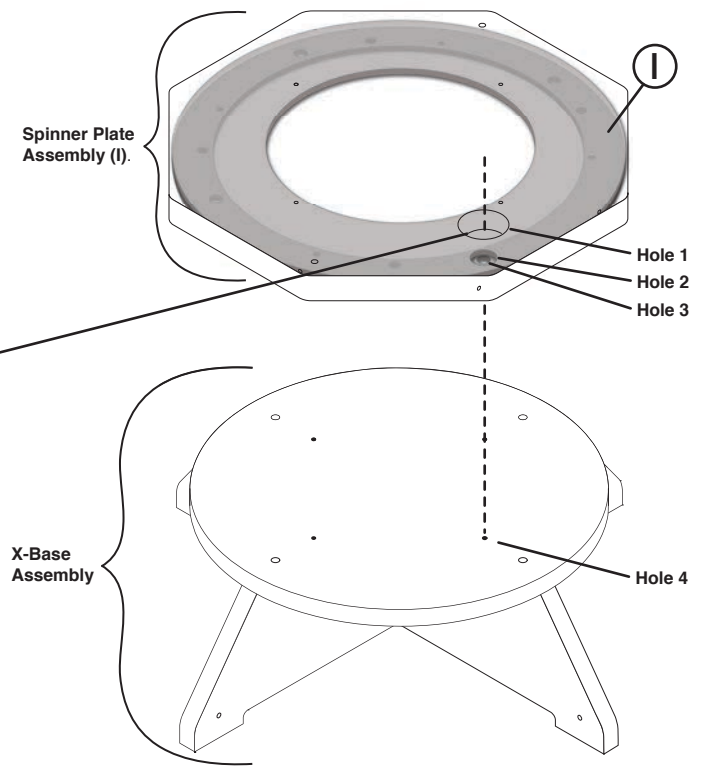
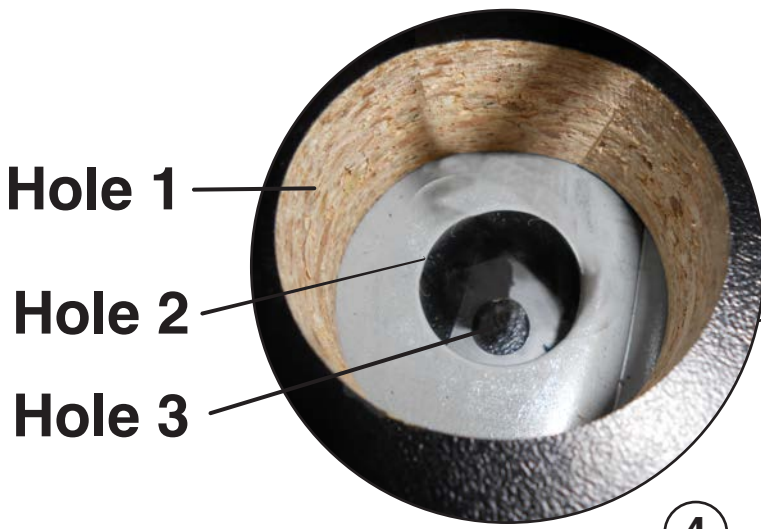
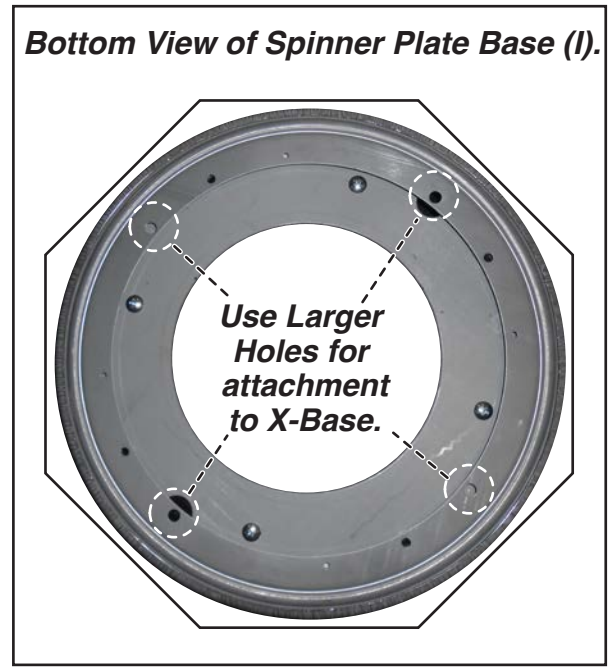
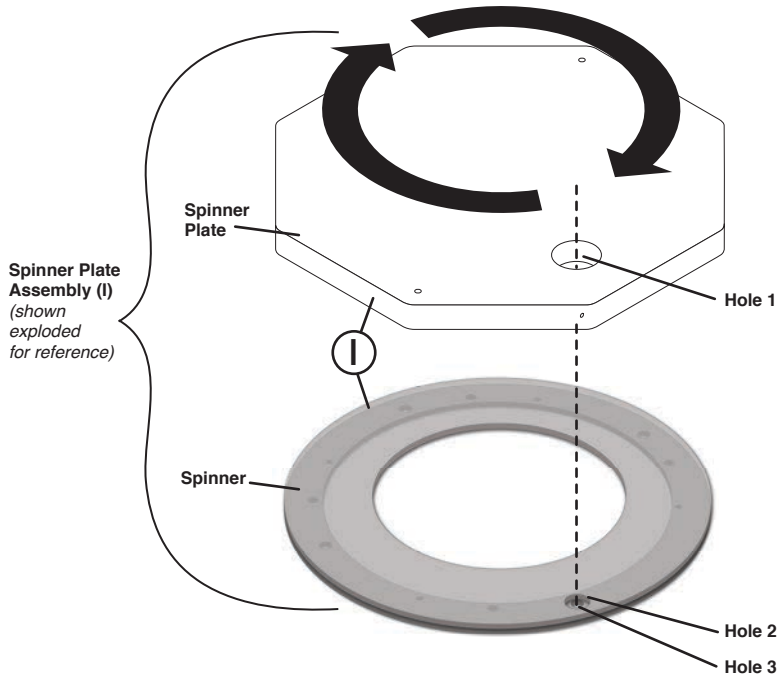

4 Align large screw holes on **Spinner Plate Assembly (I)** with one of the four corresponding holes on the **X-Base Assembly**.

ASSEMBLY

- 5** Attach **Spinner Plate Assembly (I)** to **X-Base Assembly** by using (1) **Short Trusshead Screw (D)** through large screw hole in **Spinner Plate (I)** to hole in **X-Base Assembly**. **DO NOT** tighten completely!

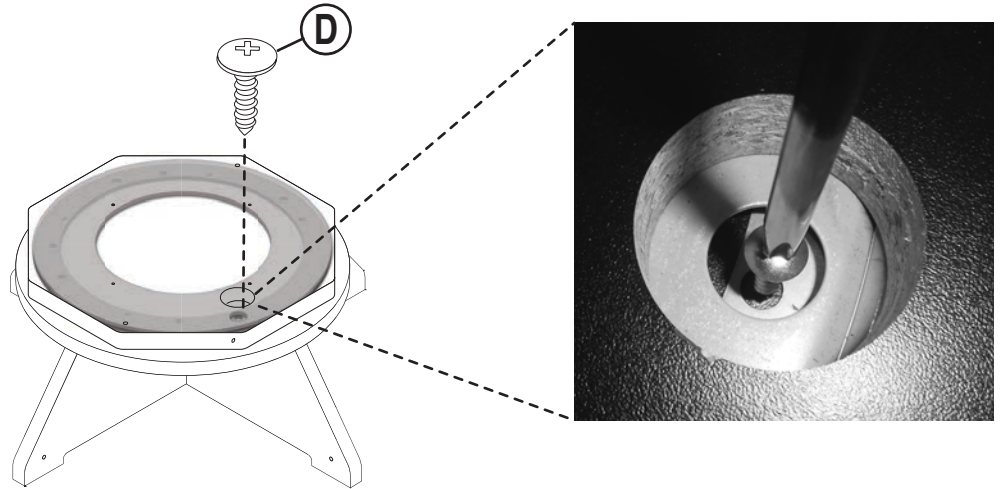

- 6** Turn **Spinner Plate Assembly (I)** 90° to continue attachment to **X-Base Assembly**, slight positioning adjustment may be necessary to find hole. To attach **Spinner Plate (I)**, use 2nd **Short Trusshead Screw (D)** through large hole to corresponding hole of X-Base Assembly.

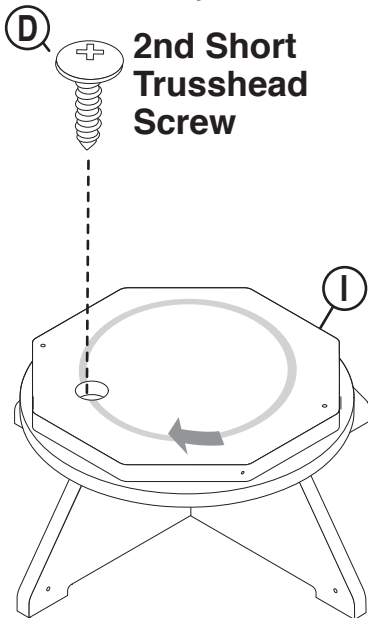

- 7** Repeat Step 6 for attaching **Spinner Plate Assembly (I)** to **X-Base Assembly** using 3rd & 4th **Short Trusshead Screws (D)**. Tighten all screws

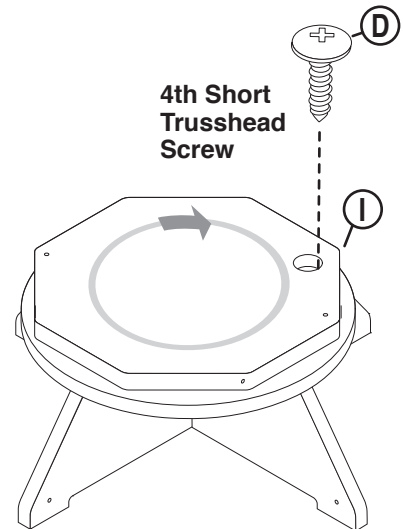
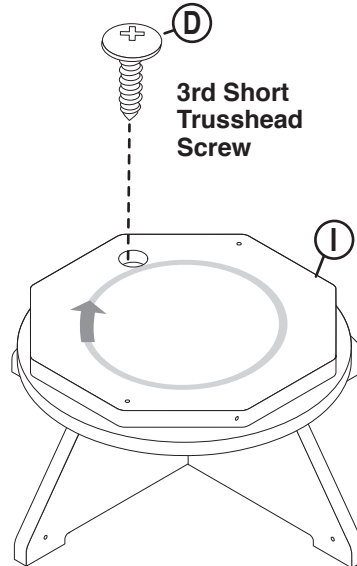

STOP! If you are installing casters, please refer to instruction sheet #14532 enclosed in your caster kit.

If you have any questions or need replacement parts, please call:

UPC Customer Service

1-800-859-7442

Design & Manufacture

ASSEMBLY

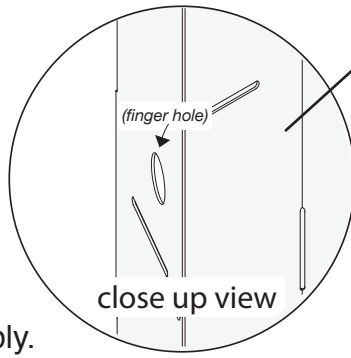

- 9** A. Peel protective masking off **Tower Panels (H)** before assembly.
- B. Overlap each **Tower Panel (H)** so the large hole of facet lies outside the small hole of adjacent panel. (see figure RIGHT)
- C. Use Large Finger Holes (see figure RIGHT) to hold **Tower Panels (H)** tightly together while installing **Push Pins (A)**.
- D. Join (2) **Tower Panels (H)** together using (8) **Push Pins (A)**. (see figure BELOW)

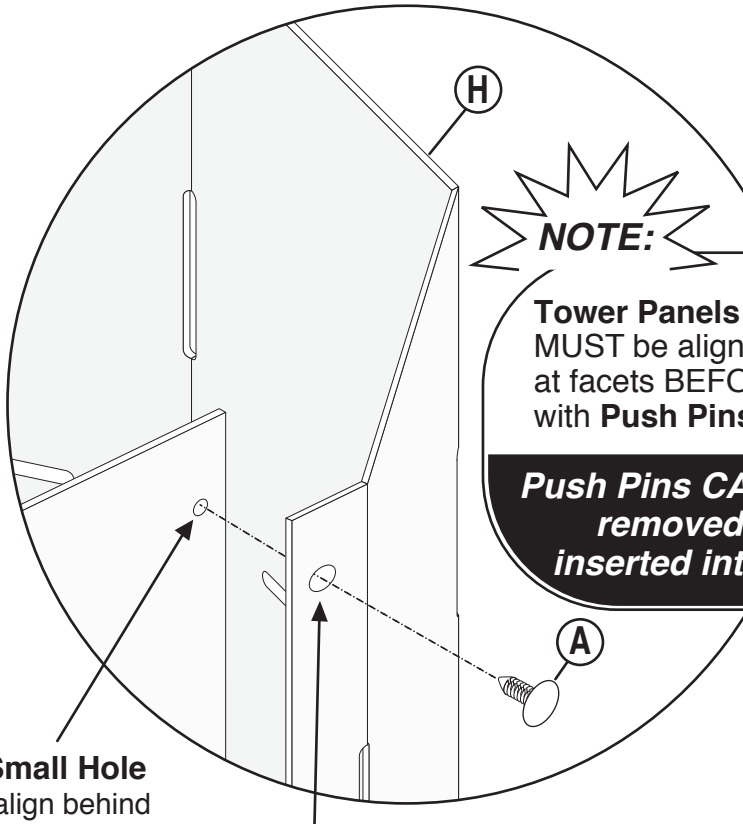
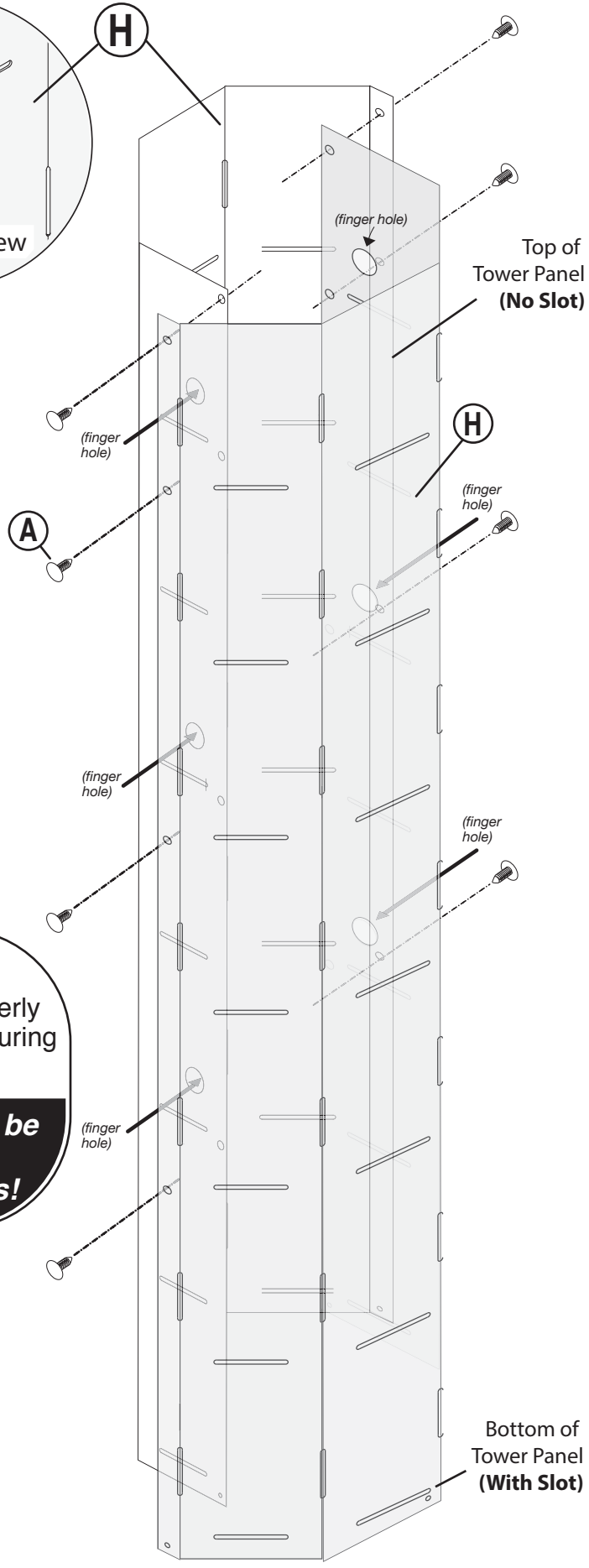

NOTE:
Tower Panels (H) MUST be aligned properly at facets BEFORE securing with Push Pins (A).
Push Pins CANNOT be removed once inserted into holes!

Small Hole
(align behind Large Hole)

Facet with Large Hole
(align in front of Small Hole)

If you have any questions or need replacement parts, please call:

UPC Customer Service

1-800-859-7442

Design & Manufacture

ASSEMBLY

- 10** This step will support **Tower Panel Assembly (H)** up for installation to Base Assembly. Insert (2) **Tower Helpers (N)** in-between **Spinner Plate Assembly (I)** and **Base (J)**, as shown below.

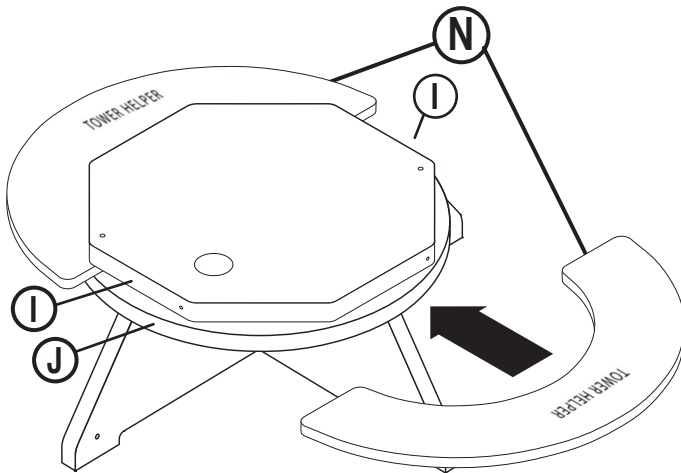

11

- Align corresponding holes and set the **Tower Panel Assembly (H)** onto the Base Assembly.

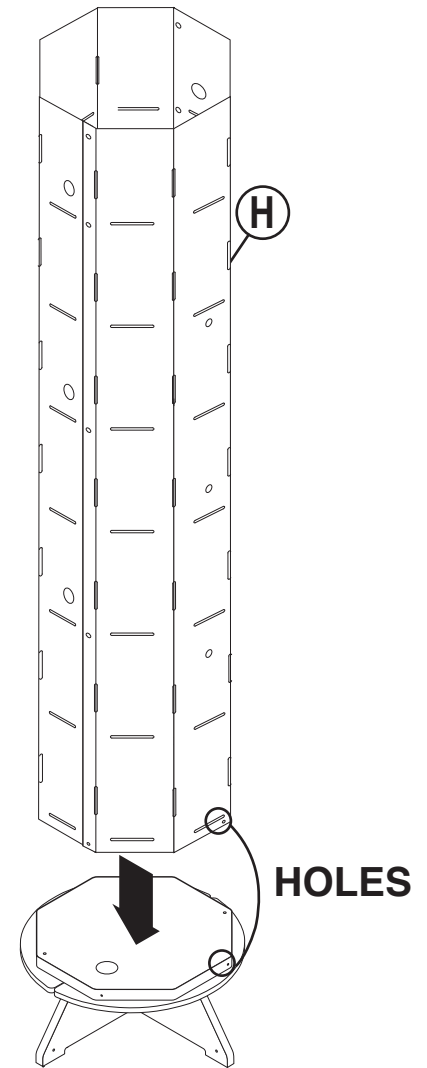

- 12** Secure **Tower Panel Assembly (H)** to Base Assembly at middle holes of Tower Panel Assembly. Attach Tower Panels to Spinner Plate edge with (2) **Long Trusshead Screws (B)**. **DO NOT** tighten completely!

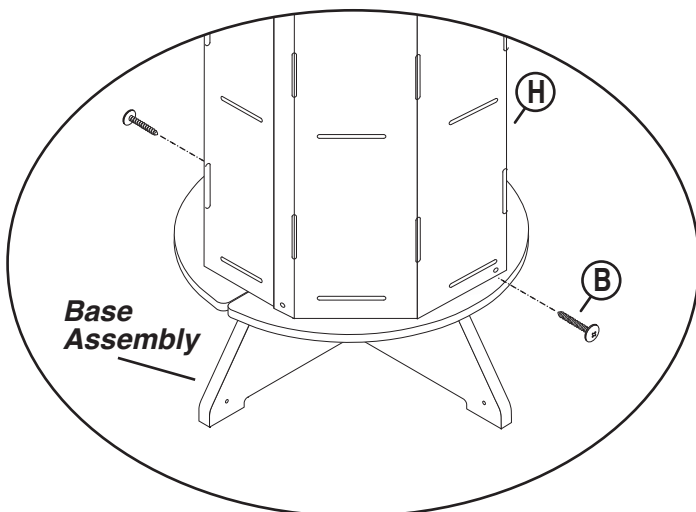

- 13** Continue to secure **Tower Panel Assembly (H)** to Base Assembly at corner holes of Tower Panel Assembly. Attach panels to Spinner Plate edge with (2) **Long Trusshead Screws (B)**. Tighten all (4) securely.

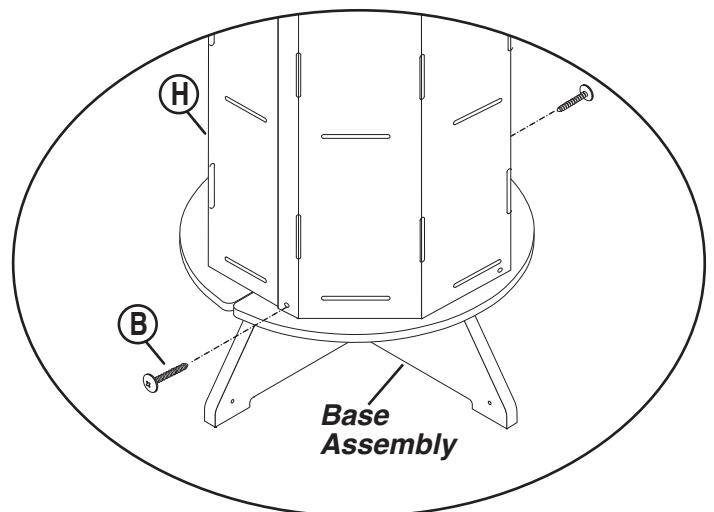

ASSEMBLY

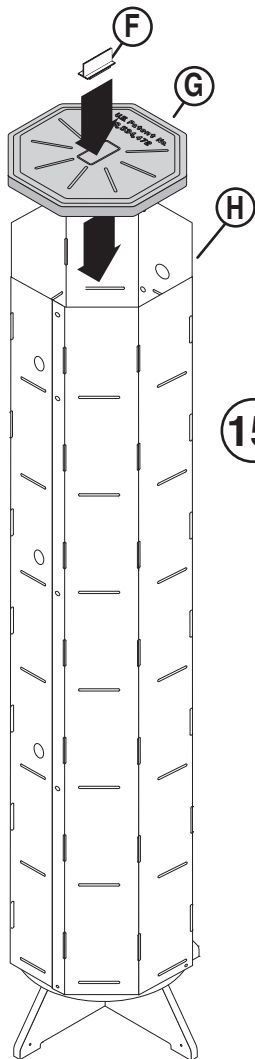

- 15** Peel masking off **Header Clip (F)** and secure to the center of the **Top Cap (G)**.

Lower **Top Cap (G)** on to the top of the **Tower Panel Assembly (H)**.

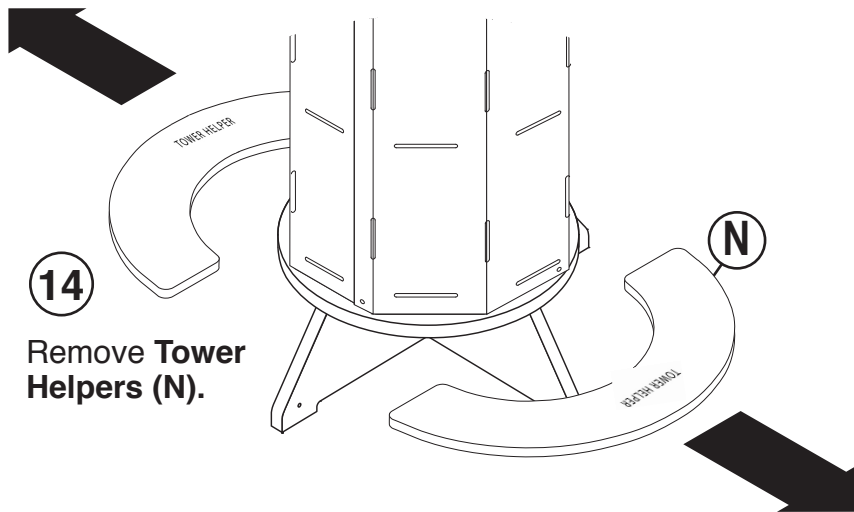

- 14** Remove **Tower Helpers (N)**.

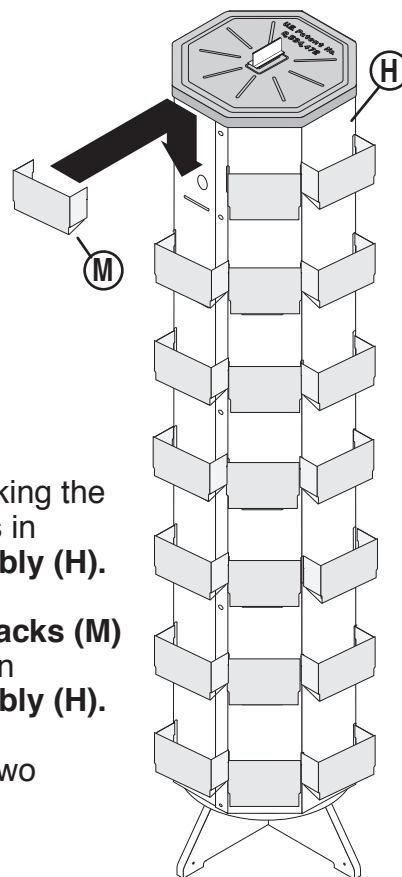

- 16** Attach **Racks (M)** by hooking the tabs into the vertical slots in the **Tower Panel Assembly (H)**.

Lock bottom tongue of **Racks (M)** into the horizontal slots on the **Tower Panel Assembly (H)**.

Each Vertical Slot holds two **Racks (M)** side by side.