

ASSEMBLY INSTRUCTIONS

Thank you for your purchase of one of many fine products designed & manufactured by UPC. We have made every effort to make your assembly easy, clear & hassle free. For more information or if you have any questions contact customer service at 1-800-859-7442.

PARTS BAG UPC 1454A Icon 48 Pocket Spinner

PART	Quantity	Reference
Push Pin	9 (1 extra)	A
Long Trusshead Screw	4	B
Connector Bolt	4	C
Short Trusshead Screw	4	D
Hex Wrench	1	E
Header Clip	1	F

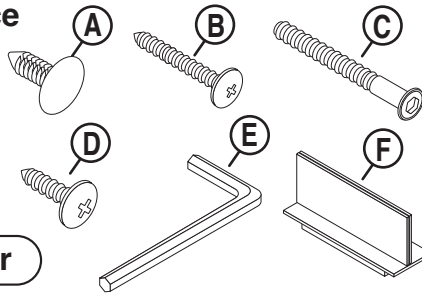

TOOLS REQUIRED: #2 Phillips Screwdriver

PARTS LIST

PART	Quantity	Reference
Top Cap	1	G
Tower Panel	2	H
Spinner Plate	1	I
Base	1	J
X-Base Lower	1	K
X-Base Upper	1	L
Pockets	48	M
Tower Helper	3	N

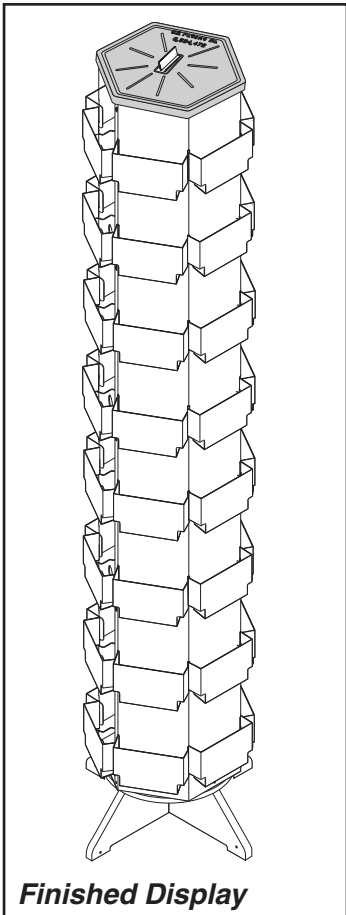
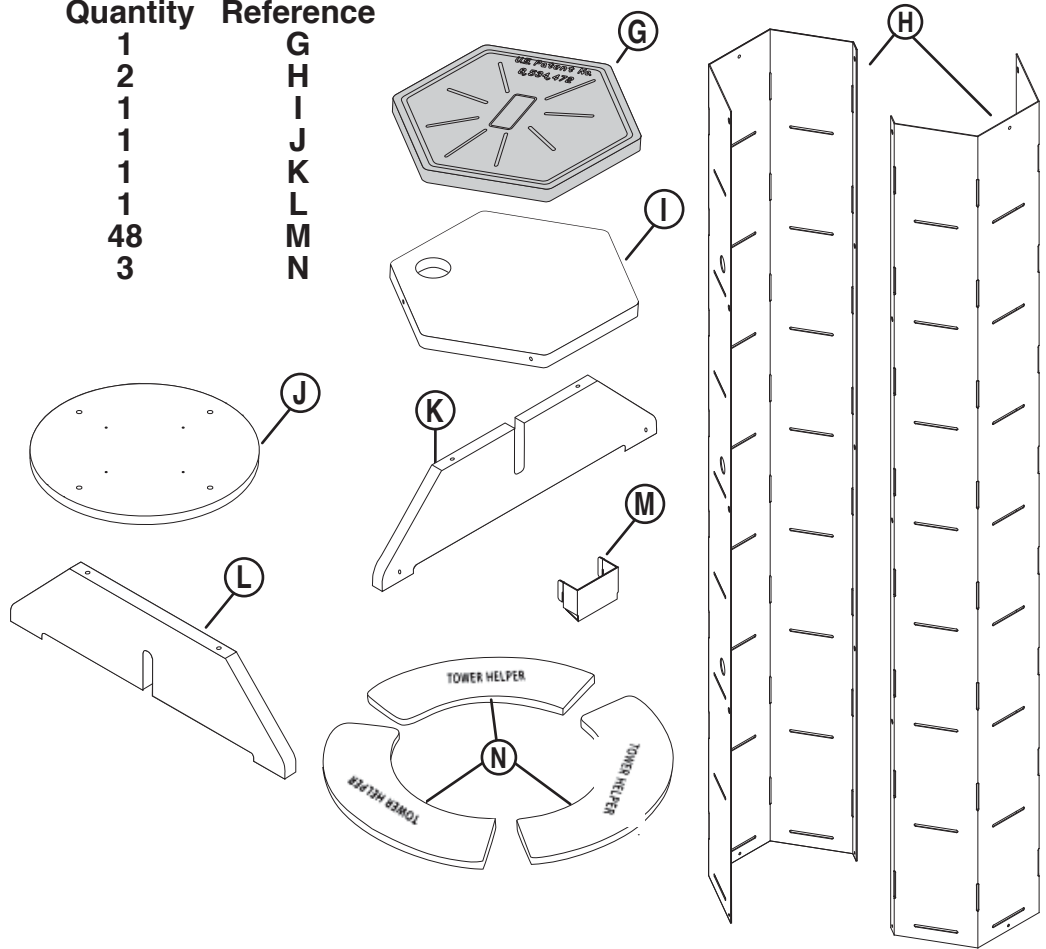

YouTube

Instruction Video

Watch our easy
to follow
instruction video

www.upcdisplays.com/1454A.html

If you have any questions or need replacement parts, please call:

UPC Customer Service
1-800-859-7442

Design & Manufacture

ASSEMBLY

- 1** Insert **X-Base Upper (L)** into **X-Base Lower (K)** as shown below.

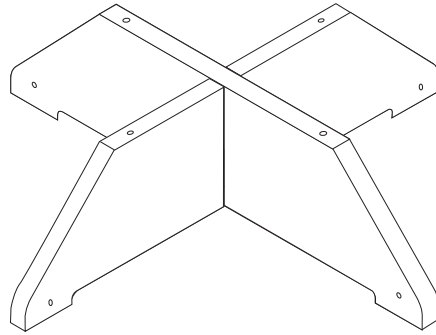
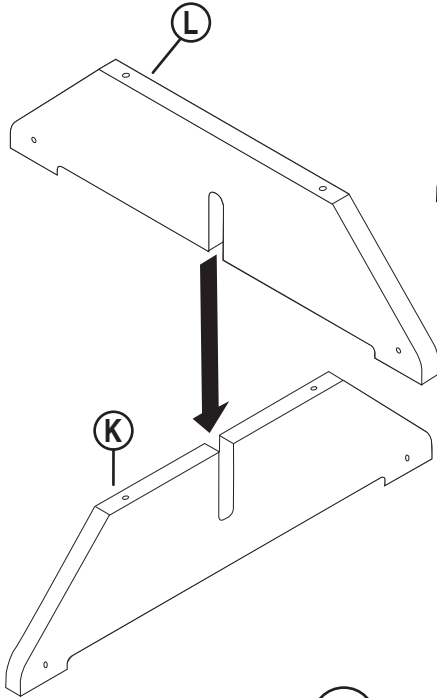

- 2** Attach **Base (J)** to **X-Base Assembly (K/L)** using **(4) Connector Bolts (C)**.

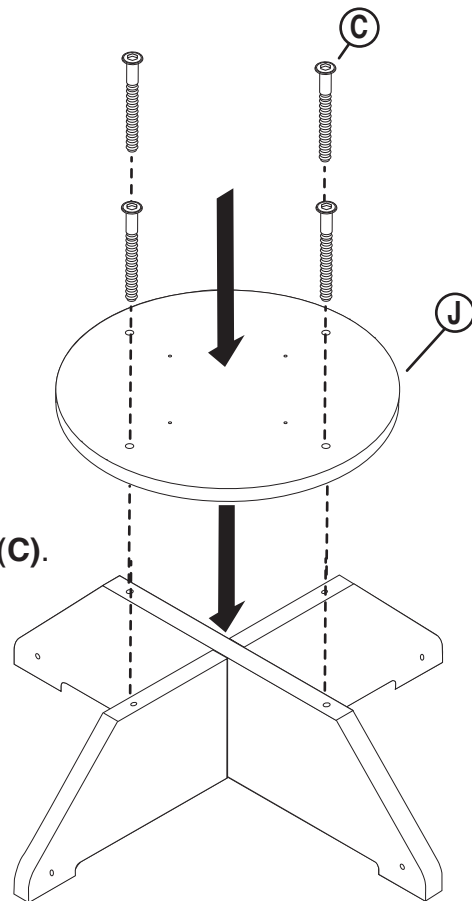

ASSEMBLY

3 Spin & align the large holes in **Spinner Plate** and **Spinner**.

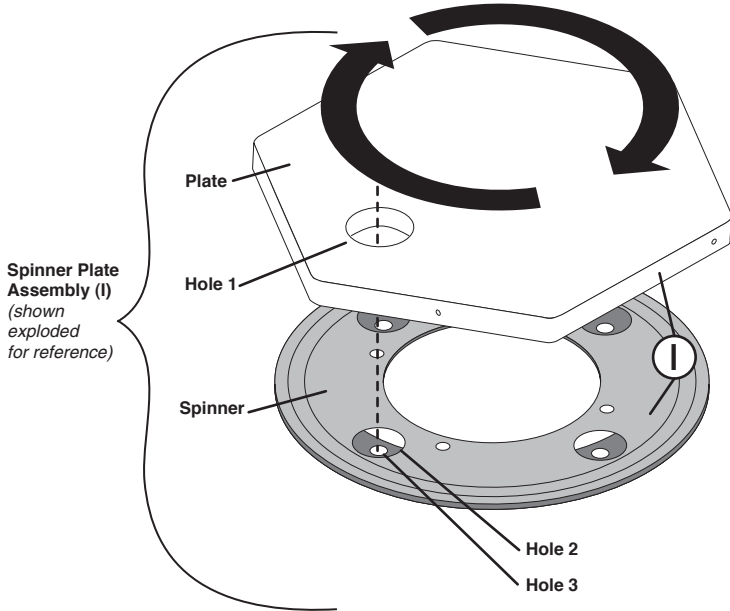

Bottom View of Spinner Plate Base (I).



Hole 1

Hole 2

Hole 3

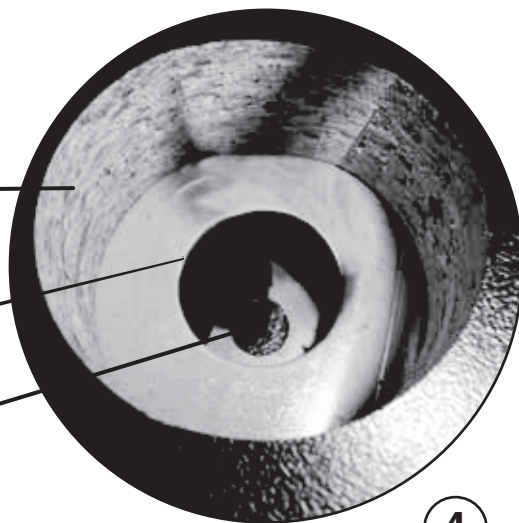

4

Align large screw holes on **Spinner Plate Assembly (I)** with one of the four corresponding holes on the **X-Base Assembly**.

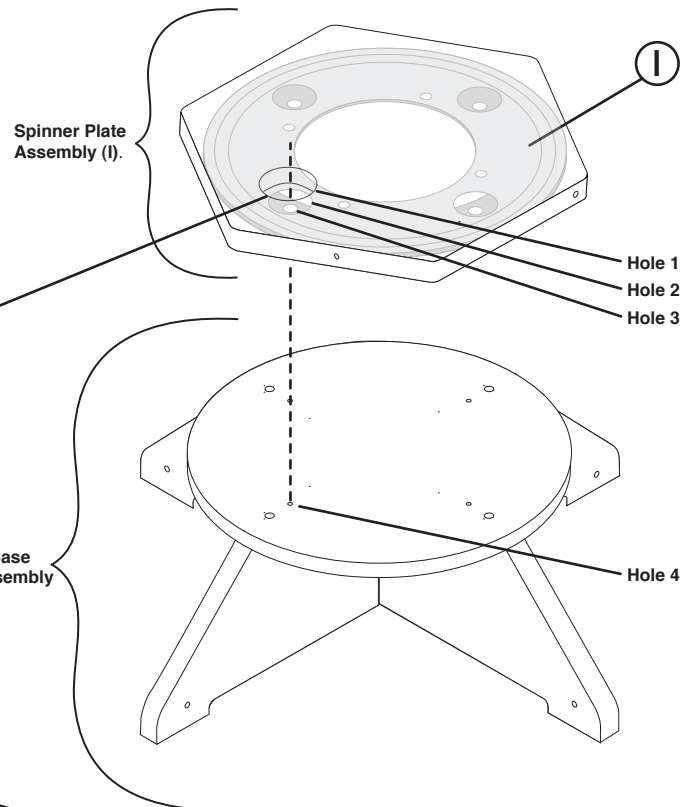

ASSEMBLY

- 5** Attach **Spinner Plate Assembly (I)** to **X-Base Assembly** by using (1) **Short Trushead Screw (D)** through large screw hole in **Spinner Plate (I)** to hole in **X-Base Assembly**. **DO NOT** tighten completely!

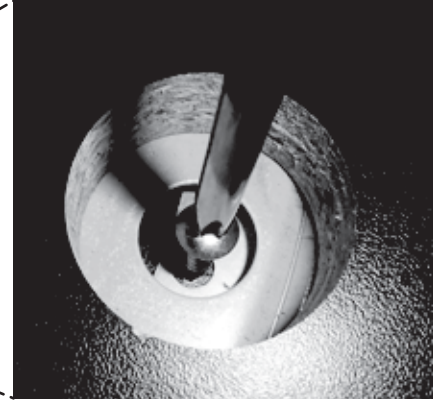
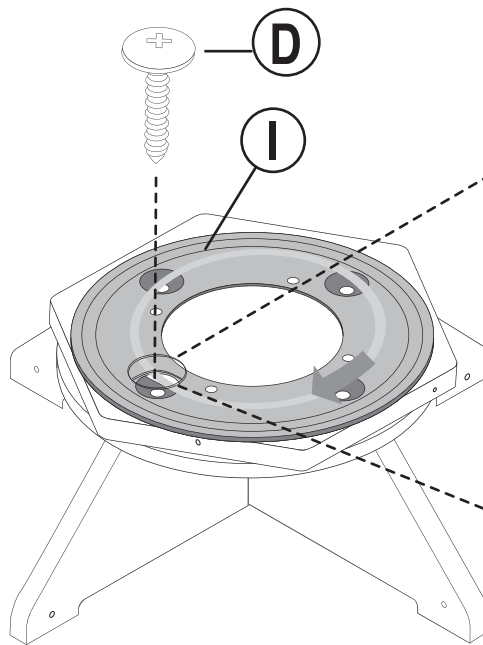

- 6** Turn **Spinner Plate Assembly (I)** 90° to continue attachment to **X-Base Assembly**, slight positioning adjustment may be necessary to find hole. To attach **Spinner Plate (I)**, use 2nd **Short Trushead Screw (D)** through large hole to corresponding hole of **X-Base Assembly**.

- 7** Repeat Step 6 for attaching **Spinner Plate Assembly (I)** to **X-Base Assembly** using 3rd & 4th **Short Trushead Screws (D)**. Tighten all screws

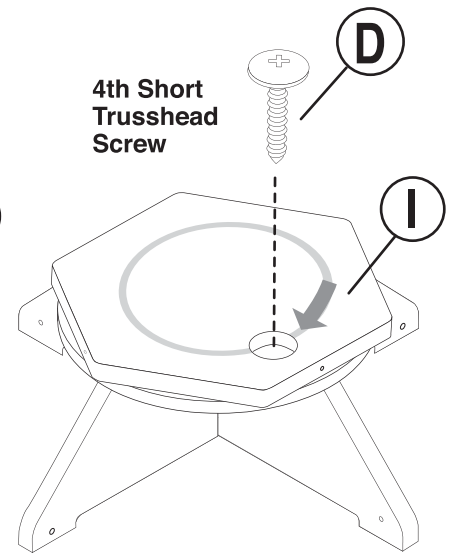
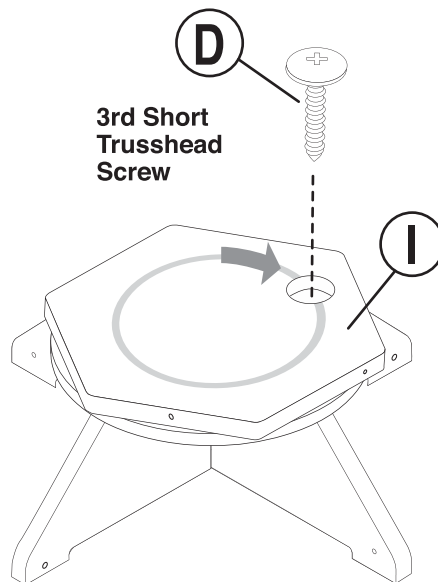
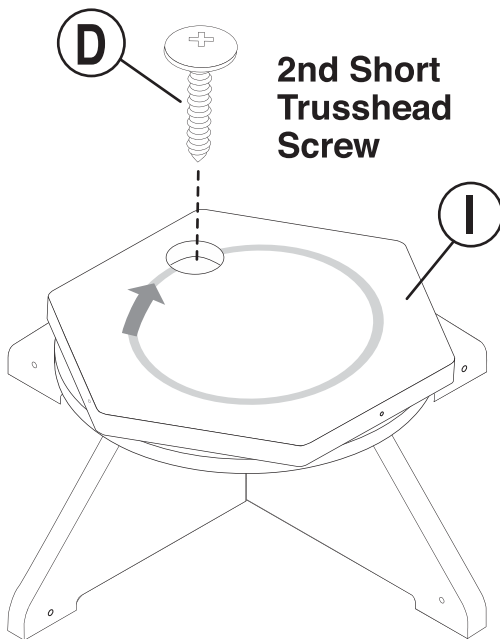

8

STOP!

STOP! If you are installing casters, please refer to instruction sheet #14532 enclosed in your caster kit.

If you have any questions or need replacement parts, please call:

UPC Customer Service

1-800-859-7442

Design & Manufacture

ASSEMBLY

- 9 A. Peel protective masking off **Tower Panels (H)** before assembly.
- B. Overlap each **Tower Panel (H)** so the large hole of facet lies outside the small hole of opposite panel. (see figure RIGHT)
- C. Use Large Finger Holes (see figure RIGHT) to hold together **Tower Panels (H)** tightly while installing **Push Pins (A)**.
- D. Join (2) **Tower Panels (H)** together using (8) **Push Pins (A)**. (see figure BELOW)

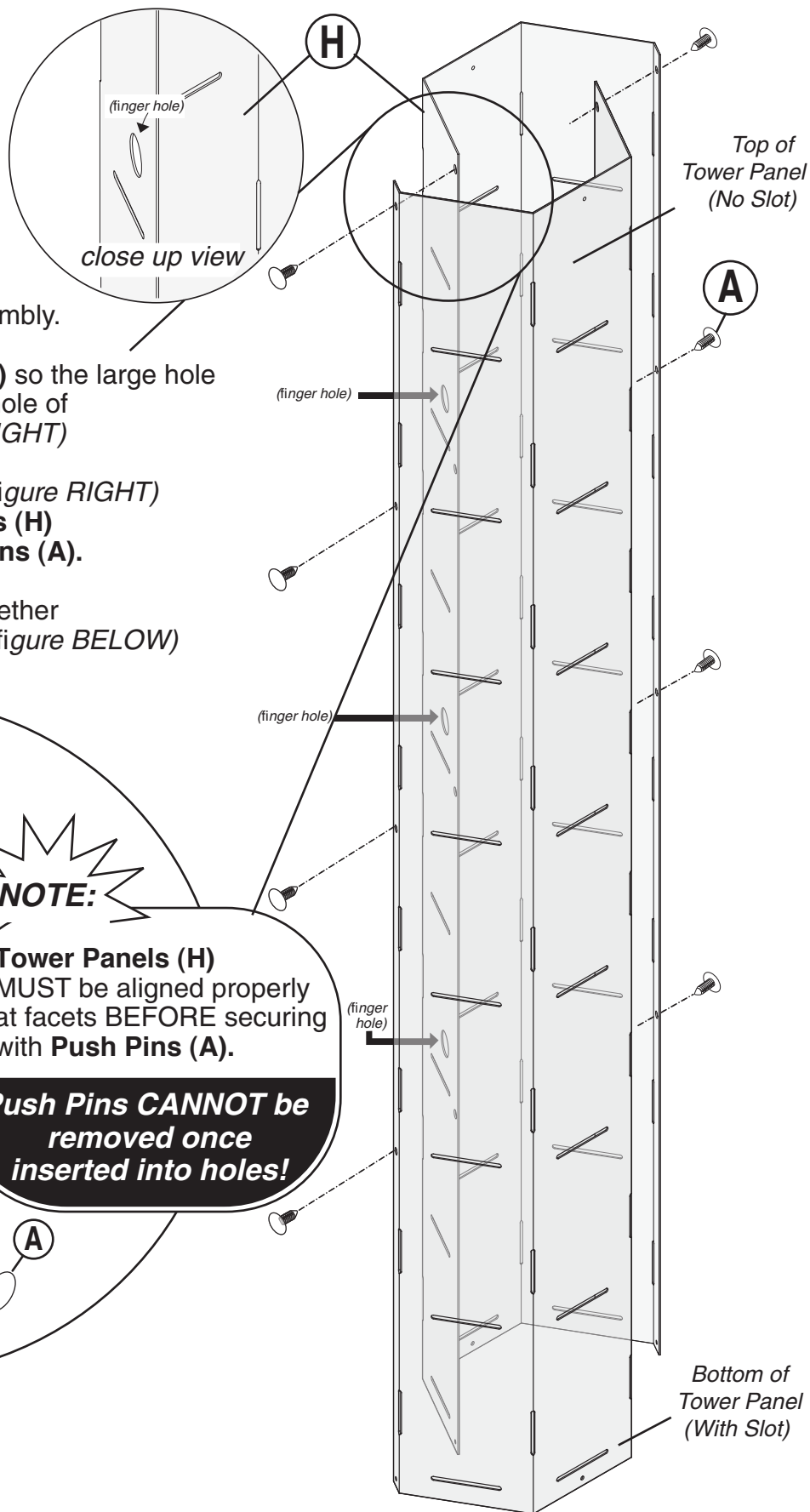

Small Hole
(align behind
Large Hole)

**Facet with
Large Hole**
(align in front
of Small Hole)

U.S. PATENT NO.
8,534,472

ASSEMBLY

- 10** This step will support **Tower Panel Assembly (H)** up for installation to Base Assembly. Insert (2) **Tower Helpers (N)** in-between **Spinner Plate Assembly (I)** and **Base (J)**, as shown below.

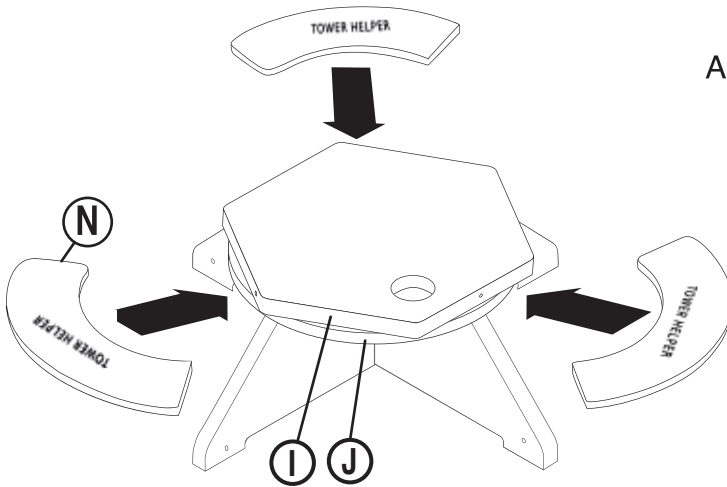

11

- Align corresponding holes and set the **Tower Panel Assembly (H)** onto the Base Assembly.

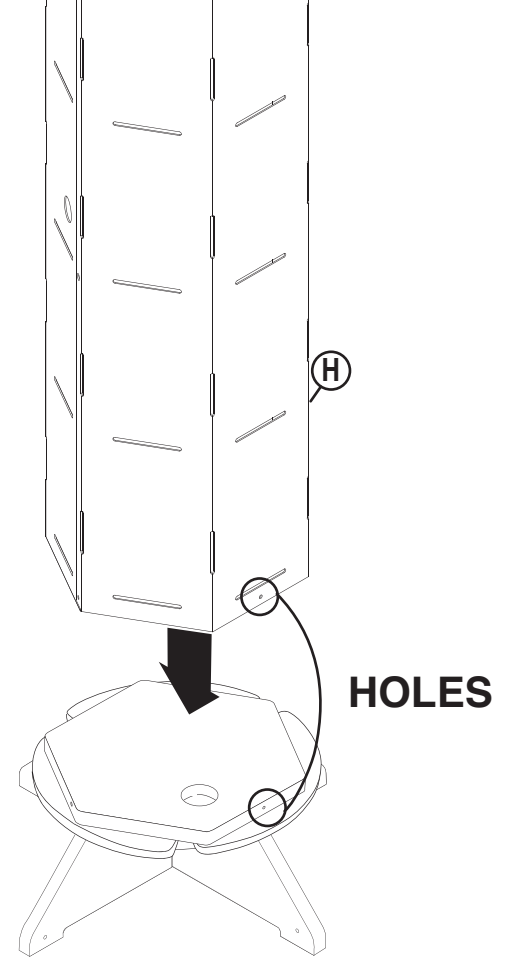

- 12** Secure **Tower Panel Assembly (H)** to Base Assembly at middle holes of Tower Panel Assembly. Attach Tower Panels to Spinner Plate edge with (2) **Long Trushead Screws (B)**. **DO NOT** tighten completely!

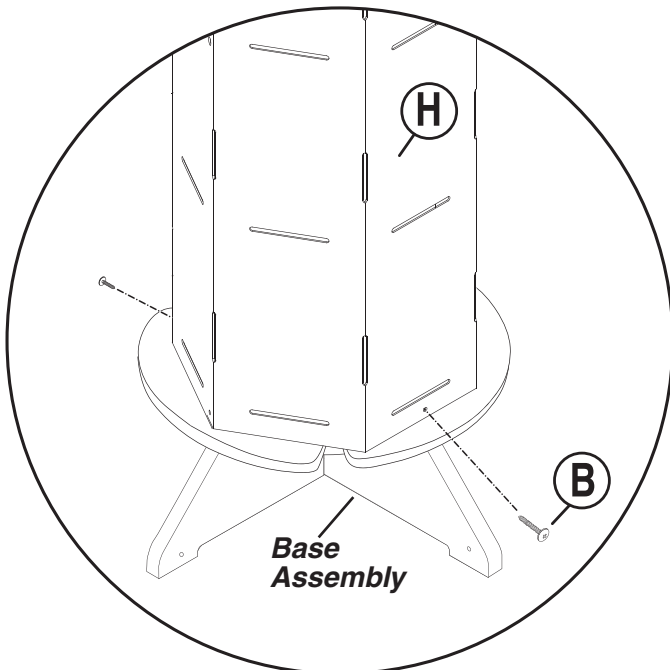

- 13** Continue to secure **Tower Panel Assembly (H)** to Base Assembly at corner holes of Tower Panel Assembly. Attach panels to Spinner Plate edge with (2) **Long Trushead Screws (B)** and tighten all (4) securely.

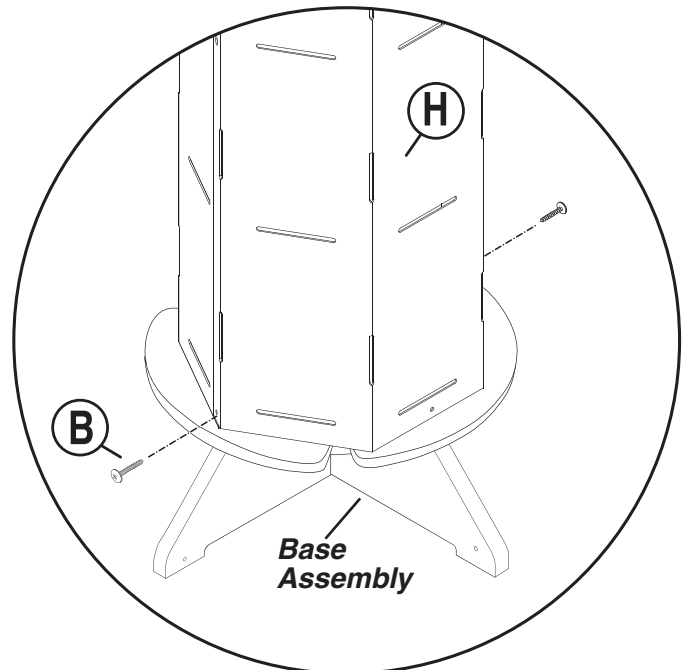

If you have any questions or need replacement parts, please call:

UPC Customer Service
1-800-859-7442

Design & Manufacture

ASSEMBLY

14

Remove **Tower Helpers (N)**.

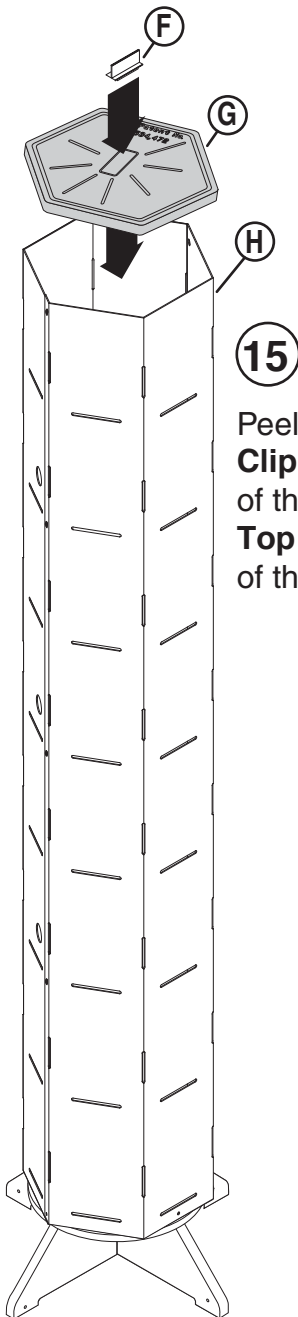
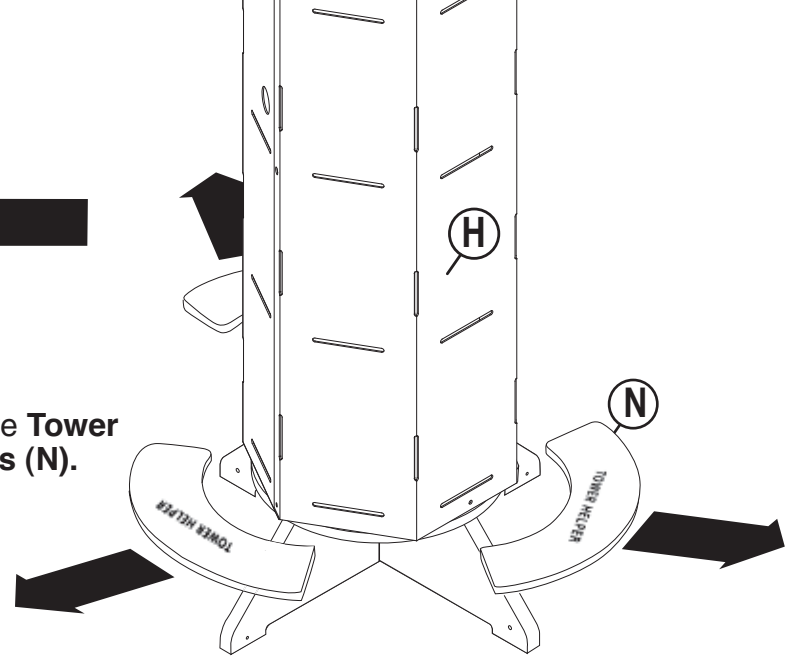

15

Peel masking off **Header Clip (F)** and secure to the center of the **Top Cap (G)**. Lower **Top Cap (G)** on to the top of the **Tower Panel Assembly (H)**.

16

Attach **Racks (M)** by hooking the tabs into the vertical slots in the **Tower Panels (H)**.

Lock bottom tongue of **Pockets (M)** into the horizontal slots on the **Tower Panels (H)**.

Each vertical slot holds two **Pockets (M)** side-by-side.

