

PARTS BAG UPC#2014B 1-Per 5" Kickout for Tiered Fixtures

PART	Quantity	Reference
Screw Post Sets	4	A
Slatwall Adapters	2	B
Phillips Panhead Screws	2	C
Wall Toggles	2	D

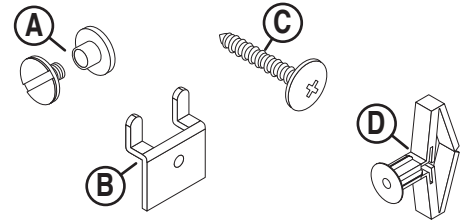

**TOOLS REQUIRED: Flathead Screwdriver (Slatwall/Drywall)
Drill with 3/8" Drywall Bit & Phillips Screwdriver (Drywall)**

PARTS LIST

PART	Quantity	Reference
Left Kickout	1	E
Right Kickout	1	F

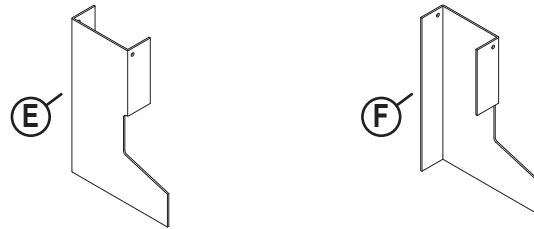

SLATWALL ASSEMBLY

NOTE: Assemble for EITHER Slatwall or Drywall, not both.

- 1 Attach **Left Kickout (E)** and **Right Kickout (F)** to **Existing or New Rack** using (2) **Screw Post Sets (A)**.
- 2 Attach the **Slatwall Adapters (B)** to **Left and Right Kickouts (E&F)** using (2) **Screw Post Sets (A)**.
Insert the entire **Rack** into the slatwall.

Note:

If you have hardware on your existing rack remove hardware before attaching kickouts and slatwall adapters.

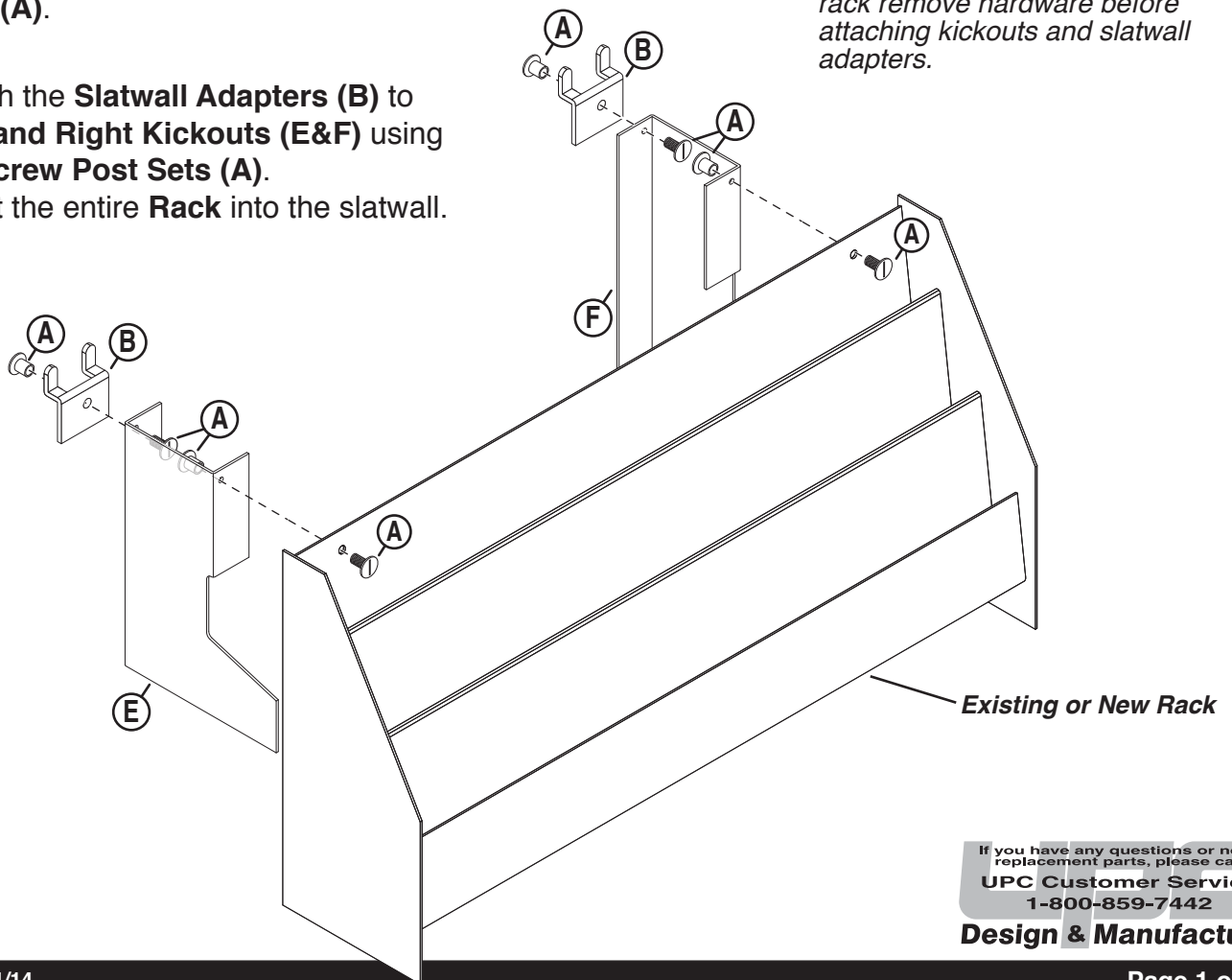

If you have any questions or need replacement parts, please call:
UPC Customer Service
1-800-859-7442

Design & Manufacture

DRYWALL ASSEMBLY

NOTE: Assemble for EITHER Slatwall or Drywall, not both.

- 1 Attach **Left Kickout (E)** and **Right Kickout (F)** to **Existing or New Rack** using (2) **Screw Post Sets (A)**.

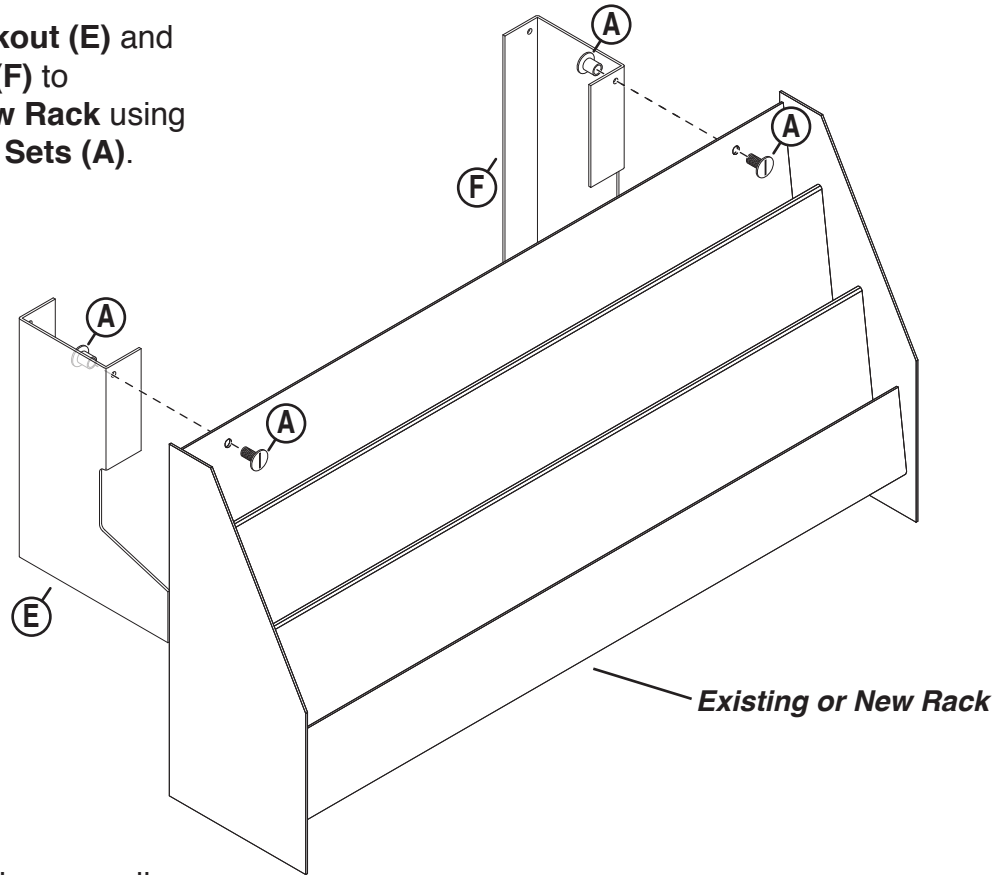

- 2 Determine position on wall and drill 3/8" holes. Squeeze **Wall Toggles (D)** flat and insert into hole. Tap flange flush with wall.

- 3 Place **Rack with Kickouts (E&F)** against **Wall Toggles (D)** and insert **Screw (C)**, tightening until secure.

