

PARTS BAG UPC 8076B 3' Slotwall Stand Alone Endcap

PART	Quantity	Reference
MiniFix Cam	6	A
Connector Bolt	12	B
Connector Screw	5	C
Leveler	4	D
Left Bracket	1	E
Right Bracket	1	F
Wood Screw	10 (1 extra)	G
Nut	4	H
Machine Screw	4	I
Key	2	J
MiniFix Cap-Bolt	6	K
Hex Wrench	1	L

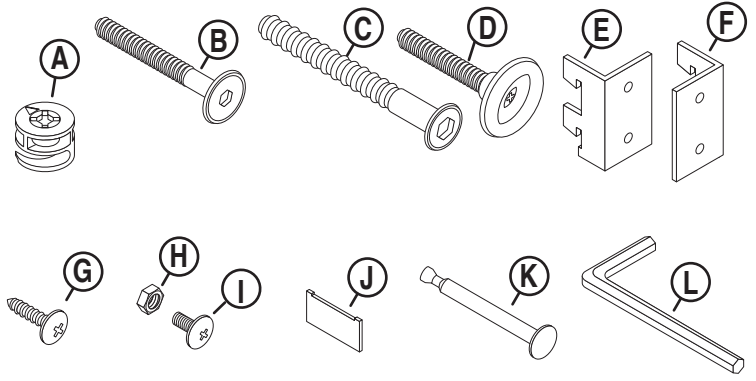

OTHER TOOLS REQUIRED: #2 Phillips & Flatblade Screwdriver

PARTS

PART	Quantity	Reference
Base Panel	1	M
Left Frame	1	N
Right Frame	1	O
Lower Front Panel	1	P
Upper Front Panel	1	Q
Top Cap	1	R
Slotted Upright	2	S
Sign Track	1	T
Lower Back Panel	1	U
Upper Back Panel	1	V
Side Panel	2	W

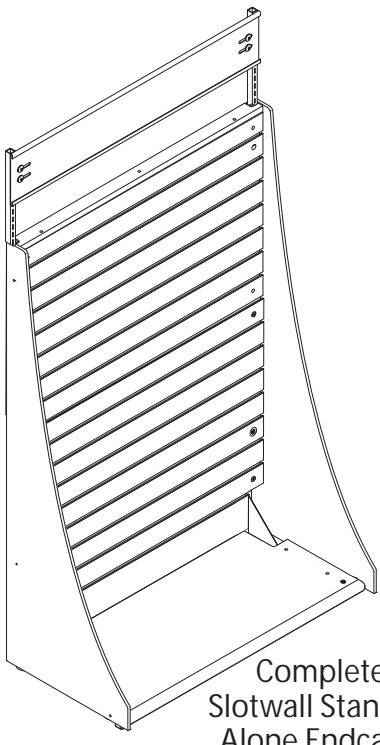
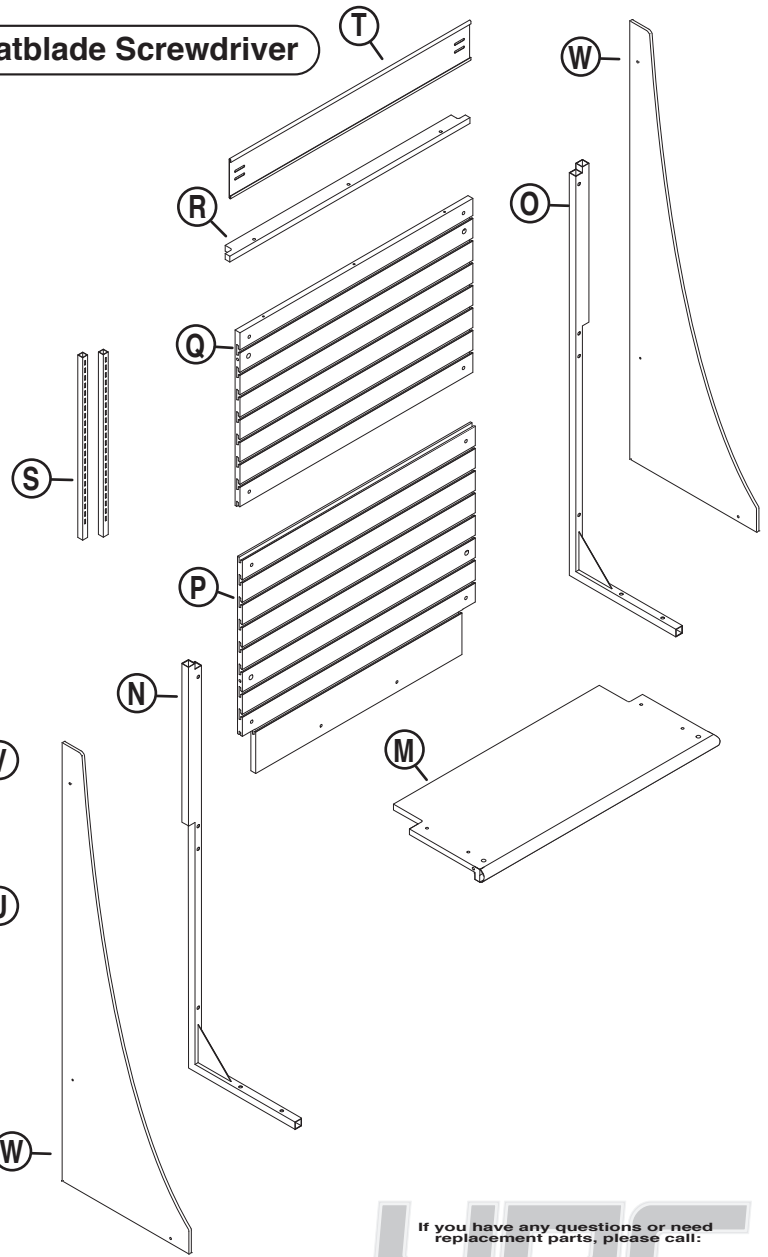

If you have any questions or need replacement parts, please call:
UPC Customer Service
 1-800-859-7442
 Design Manufacture

If you have any questions or need replacement parts, please call:

UPC Customer Service
1-800-859-7442

Design & Manufacture

ASSEMBLY

- 1 Screw (4) **Levelers (D)** into threaded holes in bottom of **Left Frame (N)** & **Right Frame (O)**. Attach **Base Panel (M)** to base of **Left Frame (N)** and **Right Frame (O)** using (4) **Connector Bolts (B)**.

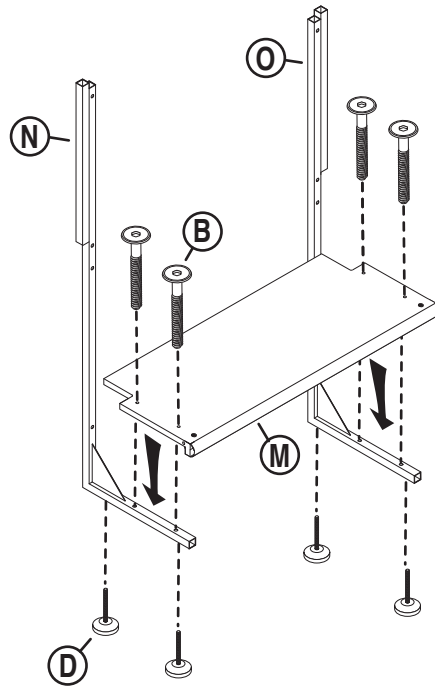

- 2 Slide **Lower Front Panel (P)** down into base assembly and attach using (4) **Connector Bolts (B)** from front. Move to back of assembly and attach **Lower Front Panel (P)** to **Base Panel (M)** using (2) **Connector Screws (C)**. Do not tighten all bolts until **Upper Front Panel (Q)** is installed.

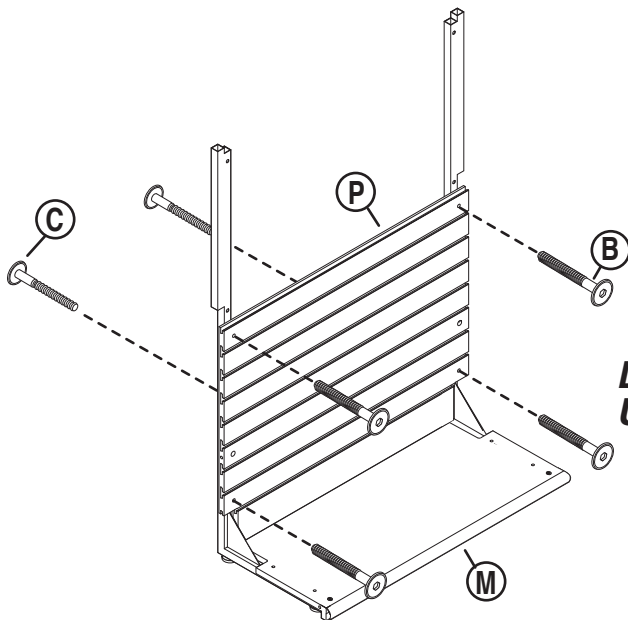
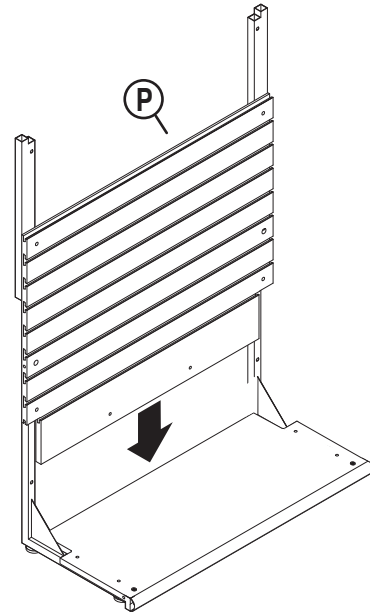

Do not tighten all bolts until Upper Front Panel (Q) is installed.

If you have any questions or need replacement parts, please call:

UPC Customer Service
1-800-859-7442

Design & Manufacture

ASSEMBLY

- 3 Attach **Upper Front Panel (Q)** to assembly using (4) **Connector Bolts (B)**. Now you may tighten all bolts.

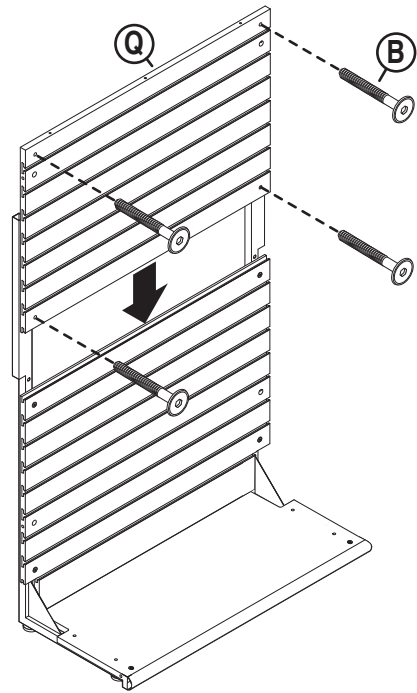

- 4 Insert (6) **MiniFix Cams (A)** into larger holes in assembly.

Point arrows on MiniFix cams toward joining holes in edge.

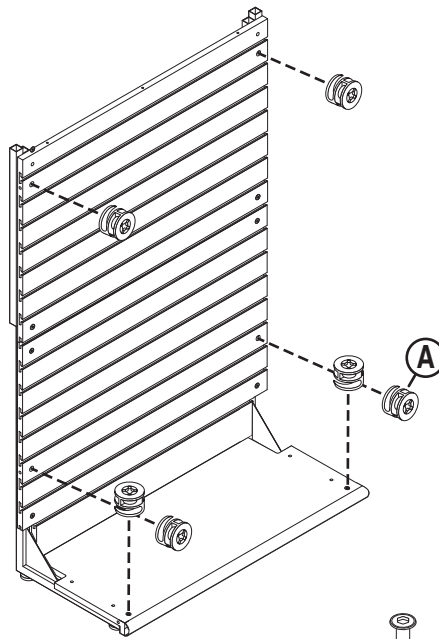

- 5 Attach **Top Cap (R)** to base assembly using (3) **Connector Screws (C)**.

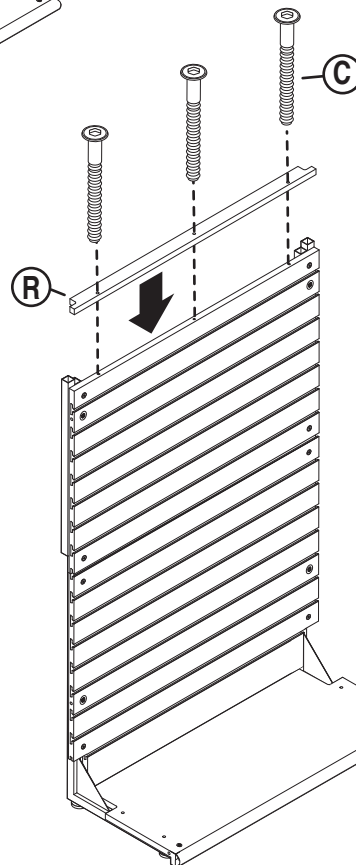

If you have any questions or need replacement parts, please call:

UPC Customer Service
1-800-859-7442

Design & Manufacture

ASSEMBLY

- 6** Attach (2) **Side Panels (W)** to assembly using (6) **MiniFix Cap-Bolts (K)** and secure by tightening (6) **MiniFix Cams (A)** installed in **Step 4**.

See MiniFix Note below.

MiniFix Note:

- 1) Install Cam Lock in holes and point arrow towards edge hole.

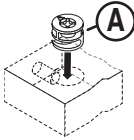

- 2) Turn Cam-Lock clockwise to Lock Cam over MiniFix Bolt.

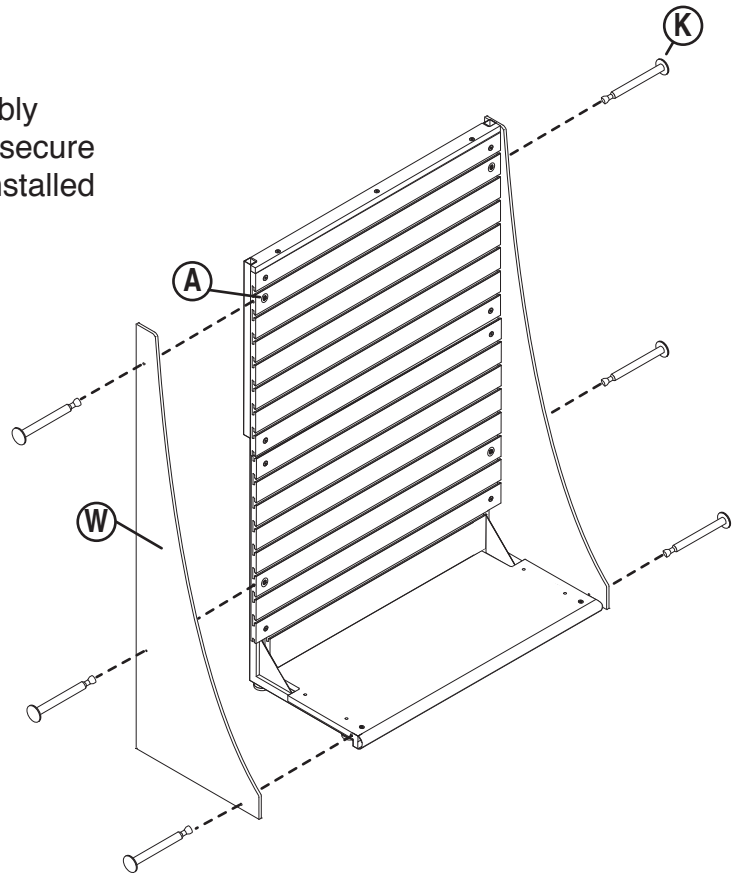
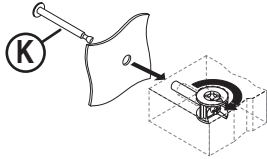

- 7** Attach **Lower Back Panel (U)** and **Upper Back Panel (V)** to assembly using (9) **Wood Screws (G)**.

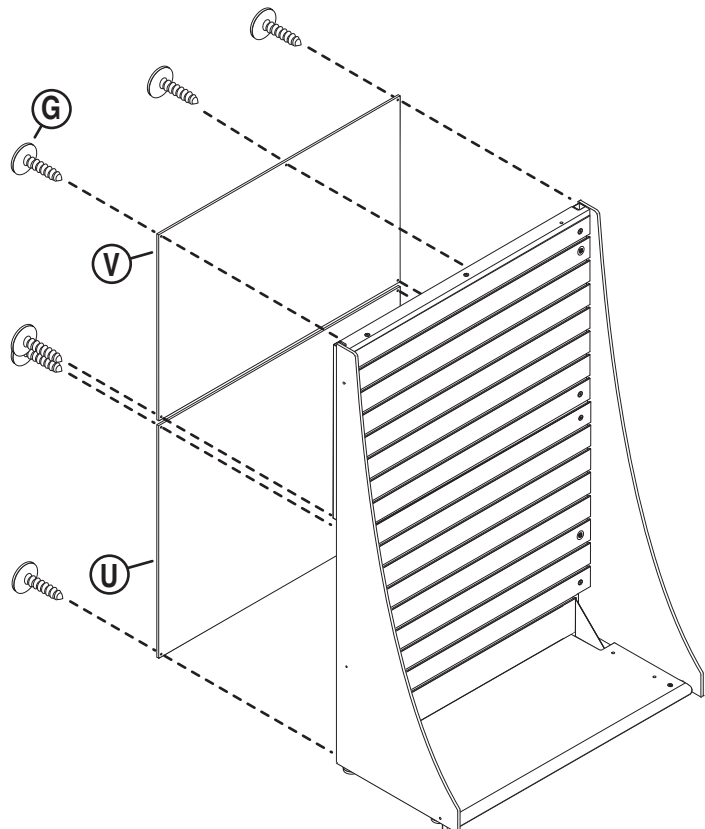

If you have any questions or need replacement parts, please call:

UPC Customer Service
1-800-859-7442

Design & Manufacture

ASSEMBLY

- 8** Insert (2) **Slotted Uprights (S)** in square holes in top of assembly and secure at desired height using (2) **Keys (J)** with indentations up.

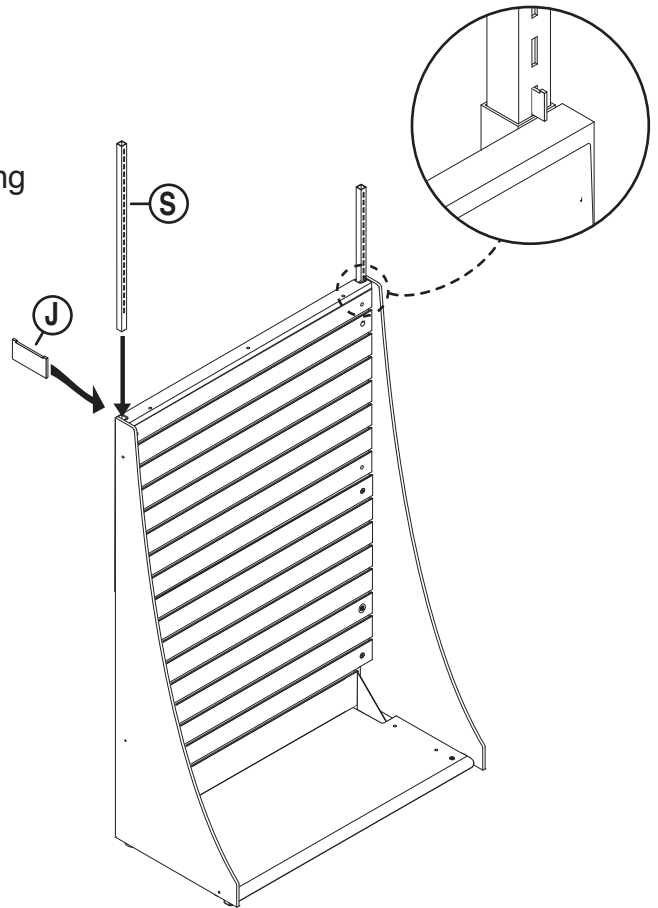

- 9** Attach **Left & Right Brackets (E&F)** to back of **Sign Track (T)** using (4) **Nuts (H)** and (4) **Machine Screws (I)**.

Be sure Bracket slots open down.

Hook **Sign Track Assembly** onto display.

