



HealthShield™ ASSEMBLY INSTRUCTIONS

PROTECTING LIVES, ONE SHIELD AT A TIME

Thank you for your purchase of one of many fine HealthShield™ products designed & manufactured by UPC. We have made every effort to make your assembly easy, clear & hassle free. For more information or if you have any questions contact customer service at 1-800-859-7442 or visit www.healthshield.care

UPC HealthShield™ #14098 / 14099 / 14100 / 14101 - Booth Shield

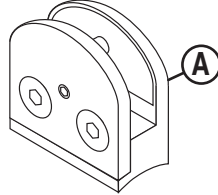
PART BAG	Quantity	Reference	
Clamp	3	A	

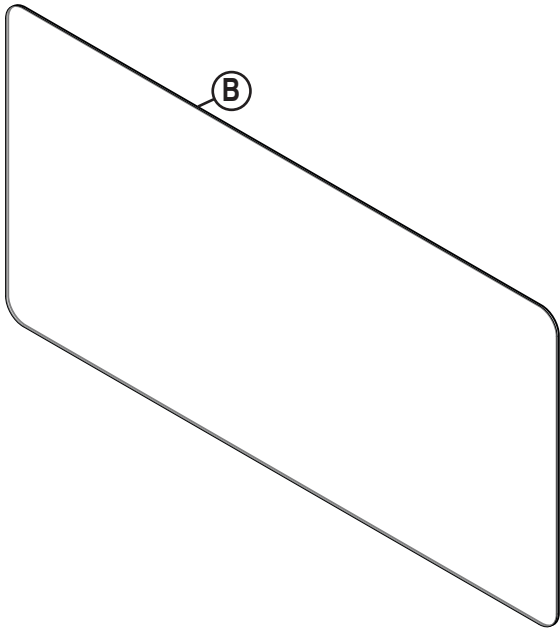
PART LIST	Quantity	Reference	
Booth Shield	1	B	

If you have any questions please call:
UPC Customer Service
1-800-859-7442
Design & Manufacture
upcdisplays.com

Clamp Instructions

- 1 Using provided *Allen Wrench*, unscrew (2) *Decorative Screws* from **Clamp (A)** and set the half and (2) *Decorative Screws* aside for later.
- 2 Remove and discard *Stabilizing Pin* from **Clamp (A)**, and remove and set *Grips* aside for later.
- 3 Screw **Clamp (A)** into place with supplied *Anchor Screw*.
- 4 Select the correct side of the *Grips* for the desired thickness of material and reinsert into both sides of **Clamp (A)**.
- 5 Insert *Material* into the single stationary side of **Clamp (A)** and hold in place.
- 6 Using provided *Allen Wrench*, screw (2) *Decorative Screws* back into **Clamp (A)** to secure *Material*.

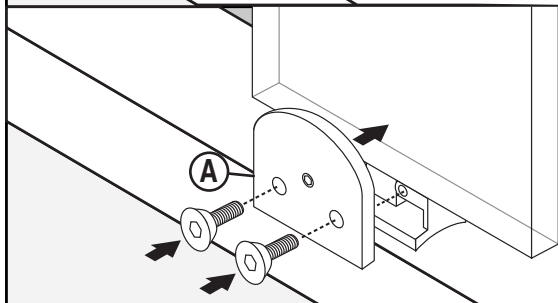
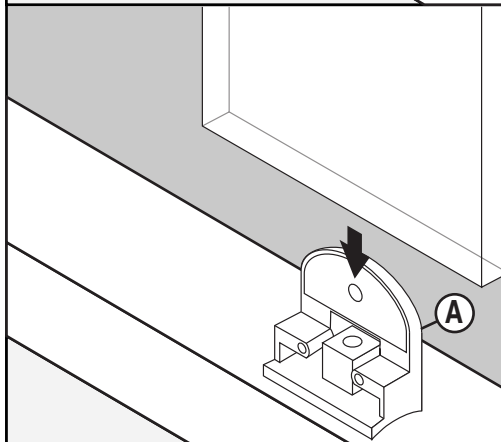
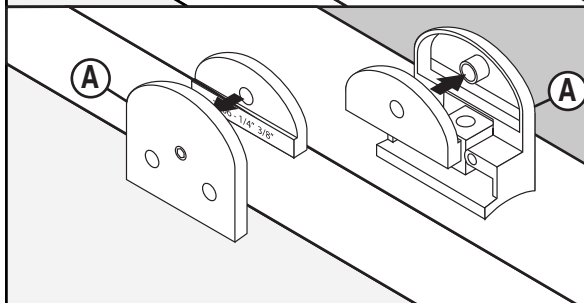
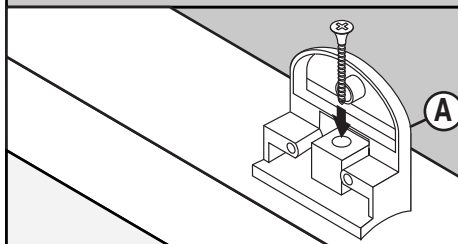
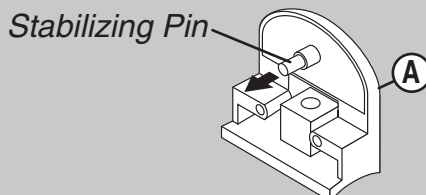
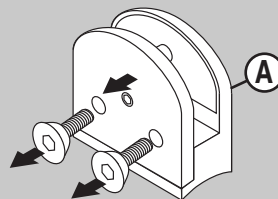

If you have any questions please call:
UPC Customer Service

1-800-859-7442
Design & Manufacture
upcdisplays.com

ASSEMBLY

- 1 Peel the *Protective Layer* from both sides of the **Booth Shield (B)**.

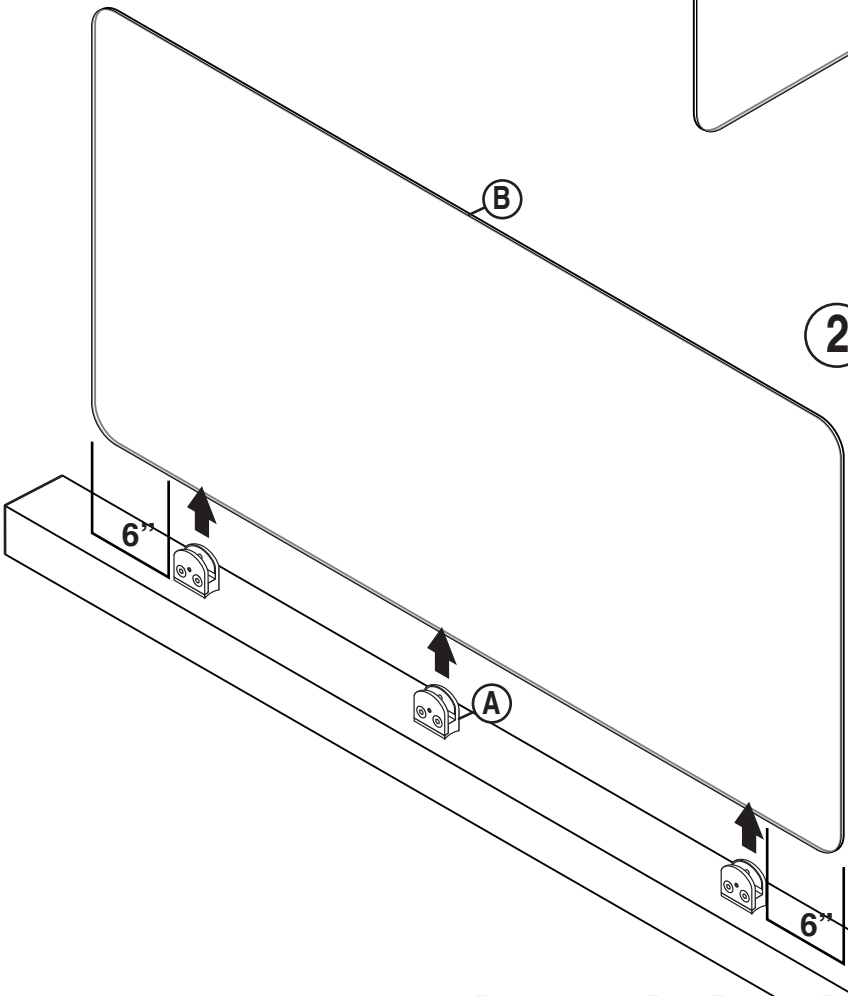
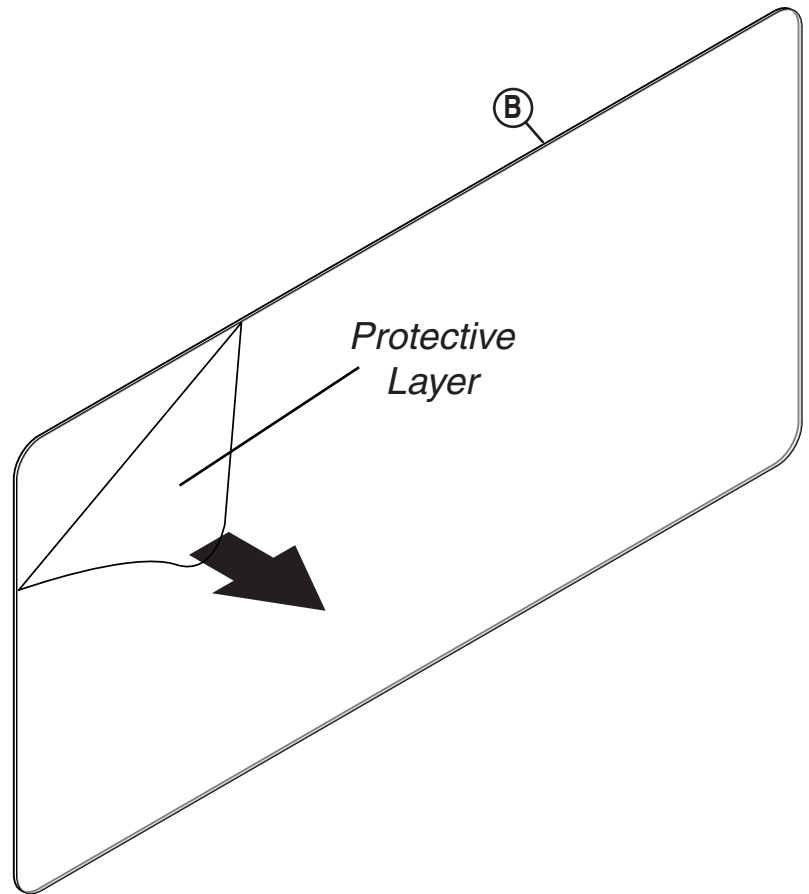

- 2 Place (3) **Clamps (A)** by following the *Clamp Instructions* on Page 2. Be sure (1) **Clamp (A)** is at the center of **Booth Shield (B)** and the (2) **Clamps (A)** are approximately 6" from each edge as shown.



www.healthshield.care

CALL TOLL FREE: 1-800-859-7442 - EMAIL: sales@upcdisplays.com

